



PARK DISTRICT of OAK PARK

PARK DISTRICT OF OAK PARK
Regular Park Board Meeting
Hedges Administrative Center
218 Madison St., Oak Park, Illinois 60302
Thursday, March 19, 2020, 7:30pm

AGENDA

- I. Call to Order/Roll Call**
- II. Approval of Agenda**
- III. Visitor/Public Comment**
Each person is limited to three minutes. The Board may set a limit on the total amount of time allocated to public comments.
- IV. Consent Agenda**
 - A. Approval of Cash and Investment Summary*
 - B. Approval of Warrants and Bills*
 - C. Approval of Minutes*
 - D. Approval of Park District Citizen's Committee New Appointment – Laura Johnson*
- V. Staff Reports**
 - A. Executive Director's Report*
 - B. Updates and Information*
 - C. Revenue/Expense Status Reports*
- VI. Old Business**
 - A. Recreation and Facility Program Committee – None
 - B. Parks and Planning Committee – Commissioner Wick
 1. CRC Architect and Engineering Services Contract Approval*
 2. CRC Construction Manager Contract Approval*
 - C. Administration and Finance Committee – Commissioner Porreca
 1. Brochure Bid Approval*
- VII. New Business**
- VIII. Commissioners' Comments**
Commissioner Porreca
Commissioner Wollmuth
Commissioner Wick
Commissioner Worley-Hood
President Lentz
- IX. Closed Session**
- X. Adjournment**

*Indicates information attached

**Indicates information/or additional information to be provided at or prior to the meeting

The Park District of Oak Park welcomes the opportunity to assist residents and visitors with disabilities.

If you need special accommodations for this meeting, please call (708) 725-2000 or via email at Karen.Gruszka@pdop.org.



Agenda Comments

Thursday, March 19, 2020

I. Roll Call

II. Approval of Agenda (Voice Vote)

No additions to the Agenda are anticipated at this time.

III. Visitor/Public Comment

IV. Consent Agenda (Roll Call Vote) – Commissioner Porreca

Commissioner Porreca – Motion of the Board for approval of the Consent Agenda, which includes the Cash and Investment Summary and Warrants and Bills for the month of February, 2020; approve minutes from the Committee of the Whole Meeting February 13, 2020, the Regular Board Meeting January 20, 2020; approval of Closed Session Minutes from February 13, 2020 and from February 20, 2020; and approve the Park District Citizen’s Committee New Appointment – Lauren Johnson.

V. Staff Reports

A. Executive Director’s Report*

B. Updates and Information*

C. Revenue/Expense Status Report*

VI. Old Business

A. Recreation and Facility Program Committee: None

B. Parks and Planning Committee: Commissioner Wick

1. CRC Architect and Engineering Services Contract Approval*

(Roll Call Vote) (attachment VI.B.1)

Commissioner Wick: I move that the Park Board approve Perkins and Will to serve as the architect on the Oak Park Community Recreation Center project along with their identified subcontractors: Terra Engineering, Altamanu, Larson Engineering and IMEG for a total cost of \$1,232,920 for the design, bid specification and construction oversight.

2. CRC Construction Manager Contract Approval*

(Roll Call Vote) (attachment VI.B.2)

Commissioner Wick: I move that the Park Board approve Bulley and Andrews to serve as Construction Manager on the Oak Park Community Recreation Center project for \$67,960 for the design and specification phase and 5.53% for the construction phase.

C. Administration and Finance Committee: Commissioner Porreca

1. Brochure Bid Contract Approval*

(Roll Call Vote) (attachment VI.C.1)

Commissioner Porreca: I move that the Park Board approve the base bid for printing the 2020-2021 from Schumann Press, Inc. from Fall River, WI, to print the Park District of Oak Park’s 2020-2021 Brochure Series in the amount of \$80,487.23. Additionally, give Executive Director Arnold authorization to extend two additional years based on the printed brochures meeting the expectations of the District.

VII. New Business

VIII. Commissioners' Comments

Commissioner Porreca

Commissioner Wollmuth

Commissioner Wick

Commissioner Worley-Hood

President Lentz

IX. Closed Session

X. Adjourn Meeting

* Indicates information attached.

** Indicates information to be provided before or at the meeting.

Update indicates verbal report provided at meeting no materials attached

In partnership with the community, we enrich lives by providing meaningful experiences through programs, parks, and facilities



CASH AND INVESTMENT SUMMARY- February 2020

	Byline	IPDLAF	CD's	PMA - SSD	IMET	Feb-20 TOTAL	Jan-20 TOTAL
General Fund							
10 - Corporate	5,583,922	8,755	(324,500)	6,838,373	(10,666,380)	1,440,170	1,249,894
Special Revenue Funds							
15 - IMRF	(1,064,147)	1,603	-	-	1,374,779	312,234	305,844
16 - Liability	(970,827)	8,965	-	-	1,124,234	162,372	140,951
17 - Audit	(57,065)	237	-	-	72,239	15,411	13,614
20 - Recreation	993,073	4,979	800,000	(67,481)	3,393,066	5,123,637	4,289,527
21 - Museum	(204,739)	1,220	-	133,871	260,161	190,513	186,577
22 - Special Recreation	(1,668,634)	17,121	-	-	1,734,237	82,725	28,622
25 - Special Facilities	149,834	3,288	-	1,040,000	593,203	1,786,325	1,677,810
85 - Cheney Mansion	207,290	462	-	-	52,326	260,079	250,862
Capital Funds							
70 - Capital Projects	172,156	78,051	500,000	80,000	1,465,901	2,296,108	2,259,263
70 - 2011 Bond	-	-	-	-	-	-	-
70 - 2012 Bond	-	-	-	-	-	-	-
70 - 2013 Bond	-	-	-	-	-	-	-
Total Cash Available to District	3,140,863	124,680	975,500	8,024,763	(596,232)	11,669,574	10,402,963
Distribution %:	26.92%	1.07%	8.36%	68.77%	-5.11%	100.00%	100.00%
Other Funds							
50 - Health Insurance Fund	246,118	345	-	-	350,799	597,263	592,259
x - Memorial Trust	14,892	-	-	-	118,163	133,056	133,018
xx - Working Cash	207,870	-	-	-	-	207,870	207,870
Total Cash Across All Funds	3,609,744	125,025	975,500	8,024,763	(127,269)	12,607,763	11,336,110



PARK DISTRICT
of OAK PARK

Park District of Oak Park
Cash Status Report
As of February 29, 2020

Operating Accounts

Byline Bank	0.15%	\$	1,938,868
iPrime Liquid Money Market	1.77%	\$	7,640,762
Illinois Metropolitan Investment Fund	1.39%	\$	1,852,888 *
Illinois Park District Liquid Asset Fund Account	0.73%	\$	125,025
		\$	11,557,542

Operating Investment Accounts

Pacific Western Bank	2.52% due 05/14/20	\$	243,800
Rockford B&TC	2.39% due 05/28/20	\$	244,000
Western Alliance Bank/Torrey Pines Bank	2.43% due 05/28/20	\$	244,000
SonaBank	2.49% due 07/13/20	\$	243,700
	Working Solvency	\$	12,533,042
	2019 Solvency	\$	13,705,194

2013 Bond Accounts

Illinois Metropolitan Investment Fund 2013 Bond	0.96%	\$	116,273 **
	2013 Bond Solvency	\$	116,273

*Includes \$226,903.62 of non-spendable funds

**Includes \$116,272.82 of non-spendable funds

IV. B

Park District of Oak Park
Voucher List for the Month of February
Presented to the Board of Commissioners
At their Meeting on March 19, 2020

Park District of Oak Park

FY 2020

AP ACCOUNT DISTRIBUTION BY ACCOUNT OPEN & PAID VOUCHERS

CHECK DATES 02/01/2020 TO 02/29/2020 PAY DATES 02/01/2020 TO 02/29/2020

BOTH ACCRUALS AND NON ACCRUALS

CHECK RUN 0 TO 2147483647

<u>VOUCHER NUMBER</u>	<u>VENDOR</u>	<u>PO NUMBER</u>	<u>CHECK NUMBER</u>	<u>PAY DATE/ CHECK DATE</u>	<u>AMOUNT</u>
10 CORPORATE FUND					
10-00-14-00040	ACCOUNTS RECEIVABLE				
37585	HUNTINGBK HUNTINGTON BANK		508548	02/14/2020	25.00
37585	HUNTINGBK HUNTINGTON BANK		508548	02/14/2020	25.00
37585	HUNTINGBK HUNTINGTON BANK		508548	02/14/2020	25.00
					<u>75.00</u>
10-00-21-20109	IMRF WITHHOLDING				
37272	IMRF ILL MUNICIPAL RETIREMENT FUND		26222	02/14/2020	47,343.65
					<u>47,343.65</u>
10-00-21-20111	HEALTH INSURANCE SECTION 125				
37362	PDRMA PDRMA		26285	02/21/2020	12,187.50
					<u>12,187.50</u>
10-00-21-20114	UNION DUES				
37305	SEIU SEIU LOCAL 73		26291	02/21/2020	292.88
					<u>292.88</u>
10-00-21-20117	AFLAC SECTION 125				
36991	AFLAC AFLAC ATTN: REMITTANCE PROCESSI		26160	02/07/2020	270.84
37301	AFLAC AFLAC ATTN: REMITTANCE PROCESSI		26242	02/21/2020	270.84
					<u>541.68</u>
10-00-21-20118	AFLAC				
36991	AFLAC AFLAC ATTN: REMITTANCE PROCESSI		26160	02/07/2020	79.78
37301	AFLAC AFLAC ATTN: REMITTANCE PROCESSI		26242	02/21/2020	79.78
					<u>159.56</u>
10-00-21-20119	I LIFE				
37304	NCPERS NCPERS GROUP LIFE INSURANCE		26280	02/21/2020	44.00
					<u>44.00</u>
10-00-21-20120	ICMA WITHHELD				
36993	ICMA ICMA RETIREMENT TRUST		26182	02/07/2020	1,845.19
37303	ICMA ICMA RETIREMENT TRUST		26273	02/21/2020	1,852.79
					<u>3,697.98</u>
10-00-21-20131	ICMA ROTH IRA WITHHELD				
36993	ICMA ICMA RETIREMENT TRUST		26182	02/07/2020	208.31
37303	ICMA ICMA RETIREMENT TRUST		26273	02/21/2020	208.31
					<u>416.62</u>
10-00-21-20132	BRIGHT START PROGRAM				
36992	BRIGHTSTA BRIGHT START COLLEGE SAVING		26166	02/07/2020	100.00
37302	BRIGHTSTA BRIGHT START COLLEGE SAVING		26246	02/21/2020	100.00
					<u>200.00</u>
10-00-52-00200	LEGAL COUNSEL				
37335	HOLLAND HOLLAND & KNIGHT LLP	20200194	26272	02/21/2020	3,266.50
					<u>3,266.50</u>
10-00-52-00202	LEGAL PUBLICATIONS				
37279	PADDOCK PADDOCK PUBLICATIONS, INC. DB20200140		26229	02/14/2020	108.00
37455	WEDNES WEDNESDAY JOURNAL	20200228	26362	02/28/2020	84.00
					<u>192.00</u>
10-00-52-00204	COMPUTER (IT) SERVICE				
37436	NOVEN NOVENTECH, INC	20200233	26342	02/28/2020	856.25

Park District of Oak Park

FY 2020

AP ACCOUNT DISTRIBUTION BY ACCOUNT OPEN & PAID VOUCHERS

CHECK DATES 02/01/2020 TO 02/29/2020 PAY DATES 02/01/2020 TO 02/29/2020

BOTH ACCRUALS AND NON ACCRUALS

CHECK RUN 0 TO 2147483647

<u>VOUCHER NUMBER</u>	<u>VENDOR</u>	<u>PO NUMBER</u>	<u>CHECK NUMBER</u>	<u>PAY DATE/ CHECK DATE</u>	<u>AMOUNT</u>
10-00-52-00204	COMPUTER (IT) SERVICE				
37527	ADOBE ADOBE SYSTEMS, INC		508490	02/14/2020	461.05
37534	AMERIEAG AMERICAN EAGLE COM SVANAC		508497	02/14/2020	500.00
37536	ARCHIVE ARCHIVE SOCIAL, INC.		508501	02/14/2020	199.00
37541	BUBBL BUBBL.US		508506	02/14/2020	59.00
37563	ESRI ENVIRONMENTAL SYSTEMS RESEARCH		508527	02/14/2020	2,500.00
37634	ONSTRAT ON STRATEGY		508593	02/14/2020	300.00
37685	USER USERECHO, LLC		508646	02/14/2020	108.00
37689	FLEETMAT FLEETMATICS USA LLC		508532	02/14/2020	1,187.00
37698	CLEVER CLEVERBRIDGE.NET		508511	02/14/2020	495.00
					<u>6,665.30</u>
10-00-52-00205	TOWNSHIP INTERVENTIONIST				
37437	OAKPKTWN OAK PARK-RIVER FOREST TOWN20200229	26343		02/28/2020	3,817.27
					<u>3,817.27</u>
10-00-52-00208	COPYING AND PRINTING- INTERNAL				
37264	DELAGE DE LAGE LANDEN PUBLIC FINANCE20200057		26215	02/14/2020	3,763.45
37596	IMPACT IMPACT NETWORKING LLC		508553	02/14/2020	4,288.13
					<u>8,051.58</u>
10-00-52-00210	POSTAGE AND DELIVERY				
37355	USPS USPS-POSTMASTER	20200203	26295	02/21/2020	240.00
37650	PITN PITNEY BOWES, INC.		508614	02/14/2020	226.04
					<u>466.04</u>
10-00-52-00299	CONTRACTUAL SERVICES - OTHER				
37026	PAYCOM PAYCOM PAYROLL, LLC		26192	02/07/2020	2,265.80
37027	PAYCOM PAYCOM PAYROLL, LLC		26192	02/07/2020	5,716.15 A
37287	TIAABANK TIAA BANK	20200056	26236	02/14/2020	1,555.09
37345	PAYCOM PAYCOM PAYROLL, LLC		26284	02/21/2020	2,518.42
37421	FLEX FLEXIBLE BENEFIT SERVICE CORP.	20200216	26332	02/28/2020	370.00
37442	PICKENS PICKENS-KANE BUSINESS SERVICE20200260		26348	02/28/2020	85.00
37460	STANDARDP STANDARD & POOR'S FINANCIA20200026		26353	02/28/2020	16,000.00
37577	GODAD GODADDY.COM		508539	02/14/2020	100.85
37684	UPS THE UPS STORE		508641	02/14/2020	720.00
					<u>29,331.31</u>
10-00-52-00650	BANK SERVICE CHARGE				
37585	HUNTINGBK HUNTINGTON BANK		508548	02/14/2020	25.00
37651	PLUNG PLUG N PAY		508615	02/14/2020	124.95
					<u>149.95</u>
10-00-53-00300	OFFICE EXPENSE				
37269	HARRIS HARRIS COMPUTER SYSTEMS MSI, I20200169		26219	02/14/2020	106.69
37573	GARVEY'S GARVEY'S OFFICE PRODUCTS		508536	02/14/2020	50.90
37573	GARVEY'S GARVEY'S OFFICE PRODUCTS		508536	02/14/2020	201.56
37573	GARVEY'S GARVEY'S OFFICE PRODUCTS		508536	02/14/2020	213.52
37594	IMPACT IMPACT NETWORKING LLC		508553	02/14/2020	1,399.95
37632	OFFMAX OFFICE MAX		508592	02/14/2020	192.80
					<u>2,165.42</u>
10-00-53-00301	UNIFORMS				
37611	LANDS LANDS END BUSINESS		508570	02/14/2020	136.98
					<u>136.98</u>

Park District of Oak Park

FY 2020

AP ACCOUNT DISTRIBUTION BY ACCOUNT OPEN & PAID VOUCHERS

CHECK DATES 02/01/2020 TO 02/29/2020 PAY DATES 02/01/2020 TO 02/29/2020

BOTH ACCRUALS AND NON ACCRUALS

CHECK RUN 0 TO 2147483647

<u>VOUCHER NUMBER</u>	<u>VENDOR</u>	<u>PO NUMBER</u>	<u>CHECK NUMBER</u>	<u>PAY DATE/ CHECK DATE</u>	<u>AMOUNT</u>
10-00-53-00405 COMPUTER EQUIPMENT					
37423	GOVCON GOVCONNECTION INC.	20200231	26335	02/28/2020	3,535.52
37424	GOVCON GOVCONNECTION INC.	20200231	26335	02/28/2020	33.82
37425	GOVCON GOVCONNECTION INC.	20200231	26335	02/28/2020	258.11
37426	GOVCON GOVCONNECTION INC.	20200231	26335	02/28/2020	299.10
37427	GOVCON GOVCONNECTION INC.	20200052	26335	02/28/2020	17.12
37523	DELL DELL BUSINESS CREDIT PAYMENT PRO		508519	02/14/2020	89.00
37621	MICRO MICROSOFT TECHNET		508580	02/14/2020	2,311.51
37621	MICRO MICROSOFT TECHNET		508580	02/14/2020	2,389.56
37622	MNJ MNJ TECHNOLOGIES DIRECT, INC.		508581	02/14/2020	6.47
37622	MNJ MNJ TECHNOLOGIES DIRECT, INC.		508581	02/14/2020	11.65
37622	MNJ MNJ TECHNOLOGIES DIRECT, INC.		508581	02/14/2020	18.00
37622	MNJ MNJ TECHNOLOGIES DIRECT, INC.		508581	02/14/2020	24.00
37622	MNJ MNJ TECHNOLOGIES DIRECT, INC.		508581	02/14/2020	29.00
37622	MNJ MNJ TECHNOLOGIES DIRECT, INC.		508581	02/14/2020	99.78
37622	MNJ MNJ TECHNOLOGIES DIRECT, INC.		508581	02/14/2020	218.97
37622	MNJ MNJ TECHNOLOGIES DIRECT, INC.		508581	02/14/2020	1,780.00
					<u>11,121.61</u>
10-00-56-00605 CONFERENCE AND TRAINING					
37257	ARNOLDJ JAN ARNOLD		26209	02/14/2020	35.00
37524	110% 110%ONLINE.NET		508488	02/14/2020	100.00
37588	HYATT HYATT HOTELS		508550	02/14/2020	183.24
37589	IAPD ILLINOIS ASSOCIATION OF PARK DISTRI		508551	02/14/2020	365.00
37603	JEWELS JEWEL - OSCO		508562	02/14/2020	60.78
37617	MANAGE MANAGEMENT ASSOCIATION NKA		508576	02/14/2020	50.00
37630	NRPA NATIONAL RECREATION & PARK ASSOC		508589	02/14/2020	3,000.00
37636	PANE PANERA BREAD		508595	02/14/2020	20.98
37640	PARKING PARKING		508597	02/14/2020	1.00
37640	PARKING PARKING		508597	02/14/2020	1.85
37640	PARKING PARKING		508597	02/14/2020	2.10
37640	PARKING PARKING		508597	02/14/2020	2.60
37640	PARKING PARKING		508597	02/14/2020	2.60
37668	SOUTHWES SOUTHWEST AIRLINES		508630	02/14/2020	448.95
37668	SOUTHWES SOUTHWEST AIRLINES		508630	02/14/2020	25.00
37668	SOUTHWES SOUTHWEST AIRLINES		508630	02/14/2020	20.00
37670	SOUTHWES SOUTHWEST AIRLINES		508630	02/14/2020	298.96
37670	SOUTHWES SOUTHWEST AIRLINES		508630	02/14/2020	25.00
37670	SOUTHWES SOUTHWEST AIRLINES		508630	02/14/2020	20.00
37741	HYATT HYATT HOTELS		508550	02/14/2020	219.74
37743	HYATT HYATT HOTELS		508550	02/14/2020	216.74
37774	PERDIEM PERDIEM		508611	02/14/2020	967.90
37778	PERDIEM PERDIEM		508611	02/14/2020	8.82
37778	PERDIEM PERDIEM		508611	02/14/2020	3.23
37778	PERDIEM PERDIEM		508611	02/14/2020	6.69
37780	PERDIEM PERDIEM		508611	02/14/2020	72.00
37780	PERDIEM PERDIEM		508611	02/14/2020	17.06
37780	PERDIEM PERDIEM		508611	02/14/2020	6.69
37781	HYATT HYATT HOTELS		508550	02/14/2020	366.48
37785	PERDIEM PERDIEM		508611	02/14/2020	6.65

Park District of Oak Park

FY 2020

AP ACCOUNT DISTRIBUTION BY ACCOUNT OPEN & PAID VOUCHERS

CHECK DATES 02/01/2020 TO 02/29/2020 PAY DATES 02/01/2020 TO 02/29/2020

BOTH ACCRUALS AND NON ACCRUALS

CHECK RUN 0 TO 2147483647

<u>VOUCHER NUMBER</u>	<u>VENDOR</u>	<u>PO NUMBER</u>	<u>CHECK NUMBER</u>	<u>PAY DATE/ CHECK DATE</u>	<u>AMOUNT</u>
10-00-56-00605 CONFERENCE AND TRAINING					
37785	PERDIEM PERDIEM		508611	02/14/2020	15.61
37785	PERDIEM PERDIEM		508611	02/14/2020	10.42
37785	PERDIEM PERDIEM		508611	02/14/2020	31.26
37786	PERDIEM PERDIEM		508611	02/14/2020	10.14
37786	PERDIEM PERDIEM		508611	02/14/2020	13.69
37786	PERDIEM PERDIEM		508611	02/14/2020	17.60
37786	PERDIEM PERDIEM		508611	02/14/2020	21.04
37786	PERDIEM PERDIEM		508611	02/14/2020	9.97
37794	PERDIEM PERDIEM		508611	02/14/2020	125.58
37795	RECCAMP REC CAMP		508618	02/14/2020	475.00
37798	SWISS SWISSOTEL CHICAGO		508636	02/14/2020	146.76
					<u>7,432.13</u>
10-00-56-00610 DUES AND SUBSCRIPTIONS					
37259	COSTCO COSTCO	20200159	26211	02/14/2020	60.00
37428	GFOA GOVERNMENT FINANCE OFFICERS ASSC	20200232	26334	02/28/2020	160.00
37590	IPRA ILLINOIS PARKS & RECREATION ASSOCI		508559	02/14/2020	279.00
					<u>499.00</u>
10-00-56-00621 DIRECTOR EXPENSE					
37543	CAPTIONS CAPTIONS AND SUBTITLE SERVICI		508508	02/14/2020	50.00
37657	REVCOM REV.COM		508620	02/14/2020	5.00
					<u>55.00</u>
10-00-56-00655 RECRUITMENT					
37553	CRAIG CRAIGSLIST.COM		508516	02/14/2020	45.00
37553	CRAIG CRAIGSLIST.COM		508516	02/14/2020	45.00
37564	FACEBOOK FACEBOOK		508528	02/14/2020	19.61
37564	FACEBOOK FACEBOOK		508528	02/14/2020	1.26
37592	IPRA ILLINOIS PARKS & RECREATION ASSOCI		508559	02/14/2020	265.00
37597	INDEED INDEED.COM		508554	02/14/2020	92.96
37597	INDEED INDEED.COM		508554	02/14/2020	502.38
37624	MONSTER MONSTER GLOBAL WORLDWIDE		508583	02/14/2020	249.00
					<u>1,220.21</u>
10-00-58-00820 TELECOMMUNICATIONS					
37258	COMCAST COMCAST	20200058	26210	02/14/2020	8,558.53
37688	VERI VERIZON WIRELESS		508648	02/14/2020	2,234.30
					<u>10,792.83</u>
10-35-52-00260 PROPERTY REPAIR					
37456	YOUNA YOUNA MECHANICAL INC	20200244	26363	02/28/2020	1,232.30
37457	YOUNA YOUNA MECHANICAL INC	20200244	26363	02/28/2020	1,819.64
37458	YOUNA YOUNA MECHANICAL INC	20200244	26363	02/28/2020	517.50
					<u>3,569.44</u>
10-35-52-00265 FLEET SERVICE					
37450	VILFLE VILLAGE OF OAK PARK FLEET	20190417	26357	02/28/2020	88.81
37452	VILFLE VILLAGE OF OAK PARK FLEET	20190417	26359	02/28/2020	207.71
					<u>296.52</u>
10-35-52-00275 CUSTODIAL SERVICES					
37260	CRYSTAL CRYSTAL MGMT & MAINTENANCE	20200148	26212	02/14/2020	410.00
					<u>410.00</u>

Park District of Oak Park

FY 2020

AP ACCOUNT DISTRIBUTION BY ACCOUNT OPEN & PAID VOUCHERS

CHECK DATES 02/01/2020 TO 02/29/2020 PAY DATES 02/01/2020 TO 02/29/2020

BOTH ACCRUALS AND NON ACCRUALS

CHECK RUN 0 TO 2147483647

<u>VOUCHER NUMBER</u>	<u>VENDOR</u>	<u>PO NUMBER</u>	<u>CHECK NUMBER</u>	<u>PAY DATE/ CHECK DATE</u>	<u>AMOUNT</u>
10-35-52-00299 CONTRACTUAL SERVICES - OTHER					
37348	PREMIERM PREMIER MECHANICAL INC	20200182	26288	02/21/2020	3,890.00
37434	MCDONTIM TIM MCDONALD	20200236	26354	02/28/2020	140.00
37655	RENTOKIL ANDERSON PEST SOLUTIONS		508500	02/14/2020	128.00
					<u>4,158.00</u>
10-35-53-00313 SUPPLIES - BUILDING MATERIALS					
37394	ARROW ARROW LOCKSMITH SERVICE	20200238	26307	02/28/2020	12.00
37429	GRAINGER GRAINGER, INC.	20200245	26336	02/28/2020	64.04
37576	GLOBALONE GLOBALONE TECHNOLOGY		508538	02/14/2020	120.00
37583	HOME HOME DEPOT		508547	02/14/2020	21.06
37584	HOME HOME DEPOT		508547	02/14/2020	294.16
37584	HOME HOME DEPOT		508547	02/14/2020	51.14
37603	JEWELS JEWEL - OSCO		508562	02/14/2020	5.28
					<u>567.68</u>
10-35-53-00320 MISCELLANEOUS SUPPLIES					
37329	FOPCON FRIENDS OF THE OAK PARK CONSERV	20200204	26266	02/21/2020	35.00
37633	OFFDEP OFFICE DEPOT		508591	02/14/2020	15.19
					<u>50.19</u>
10-35-53-00330 ANIMAL CARE					
37531	AMAZ AMAZON.COM		508496	02/14/2020	179.10
37533	AMAZ AMAZON.COM		508496	02/14/2020	59.75
					<u>238.85</u>
10-35-53-00420 FURNISHINGS					
37533	AMAZ AMAZON.COM		508496	02/14/2020	20.97
37584	HOME HOME DEPOT		508547	02/14/2020	15.60
37584	HOME HOME DEPOT		508547	02/14/2020	133.84
37694	WENSCO WENSCO OF MICHIGAN CORP		508657	02/14/2020	204.85
37694	WENSCO WENSCO OF MICHIGAN CORP		508657	02/14/2020	-15.17
					<u>360.09</u>
10-35-53-11100 GIFT SHOP					
37538	BALL BALL SEED COMPANY		508502	02/14/2020	883.28
37539	BFG BFG SUPPLY CO., LLC		508503	02/14/2020	106.92
37539	BFG BFG SUPPLY CO., LLC		508503	02/14/2020	168.90
37539	BFG BFG SUPPLY CO., LLC		508503	02/14/2020	1,285.84
37570	FOLKMAN FOLKMANIS INC.		508533	02/14/2020	250.56
37598	BFG BFG SUPPLY CO., LLC		508503	02/14/2020	76.62
37599	INGRAM INGRAM INDUSTRIES, INC.		508555	02/14/2020	25.91
37608	KINSMAN KINSMAN GARDEN CO		508567	02/14/2020	517.28
37654	INTUITMR INTUIT MR. BIRD		508557	02/14/2020	364.50
					<u>3,679.81</u>
10-35-53-11105 CONSERVATORY SPECIAL EVENTS					
37558	DOLL DOLLARTREE		508522	02/14/2020	18.00
37559	DOLL DOLLARTREE		508522	02/14/2020	45.00
37582	HOBB HOBBY LOBBY		508545	02/14/2020	107.70
					<u>170.70</u>
10-35-53-14400 BIRTHDAY PARTY SUPPLIES					
37531	AMAZ AMAZON.COM		508496	02/14/2020	119.00
37537	BALL BALL SEED COMPANY		508502	02/14/2020	140.69

Park District of Oak Park

FY 2020

AP ACCOUNT DISTRIBUTION BY ACCOUNT OPEN & PAID VOUCHERS

CHECK DATES 02/01/2020 TO 02/29/2020 PAY DATES 02/01/2020 TO 02/29/2020

BOTH ACCRUALS AND NON ACCRUALS

CHECK RUN 0 TO 2147483647

<u>VOUCHER NUMBER</u>	<u>VENDOR</u>	<u>PO NUMBER</u>	<u>CHECK NUMBER</u>	<u>PAY DATE/ CHECK DATE</u>	<u>AMOUNT</u>
10-35-53-14400	BIRTHDAY PARTY SUPPLIES				
37558	DOLL DOLLARTREE		508522	02/14/2020	144.00
37558	DOLL DOLLARTREE		508522	02/14/2020	104.00
37572	FUNEXPR FUN EXPRESS		508535	02/14/2020	231.36
37603	JEWELS JEWEL - OSCO		508562	02/14/2020	5.04
37604	JEWELS JEWEL - OSCO		508562	02/14/2020	16.25
37631	OAKBAKE OAK PARK BAKERY		508590	02/14/2020	25.38
37631	OAKBAKE OAK PARK BAKERY		508590	02/14/2020	28.50
37631	OAKBAKE OAK PARK BAKERY		508590	02/14/2020	33.84
37648	PETESFR PETE'S FRESH MARKET ROOSEVELT		508613	02/14/2020	24.25
37660	SALER SALERNO'S PIZZA		508623	02/14/2020	27.00
37660	SALER SALERNO'S PIZZA		508623	02/14/2020	28.00
37660	SALER SALERNO'S PIZZA		508623	02/14/2020	46.00
					<u>973.31</u>
10-35-56-00600	EMPLOYEE RECOGNITION				
37552	COURAGE COURAGEOUS BAKERY & CAFE		508515	02/14/2020	207.90
					<u>207.90</u>
10-35-56-00605	CONFERENCE AND TRAINING				
37011	GENTRY KENT GENTRY		26176	02/07/2020	17.41
37545	CHGOHONEY CHICAGO HONEY CO-OP		508510	02/14/2020	85.00
37626	MORTON THE MORTON ARBORETUM		508585	02/14/2020	125.00
37750	HYATT HYATT HOTELS		508550	02/14/2020	183.24
37755	IAPD ILLINOIS ASSOCIATION OF PARK DISTRI		508551	02/14/2020	55.00
37777	PERDIEM PERDIEM		508611	02/14/2020	10.26
37777	PERDIEM PERDIEM		508611	02/14/2020	5.59
37777	PERDIEM PERDIEM		508611	02/14/2020	14.53
37777	PERDIEM PERDIEM		508611	02/14/2020	11.34
37791	PERDIEM PERDIEM		508611	02/14/2020	3.07
37791	PERDIEM PERDIEM		508611	02/14/2020	4.75
37791	PERDIEM PERDIEM		508611	02/14/2020	12.01
37791	PERDIEM PERDIEM		508611	02/14/2020	36.41
					<u>563.61</u>
10-35-56-00615	EMPLOYEE TRAVEL REIMBURSEMENT				
37274	KUPPERS KRISTA KUPPERSCHMIDT		26224	02/14/2020	58.25
37330	GENTRY KENT GENTRY		26267	02/21/2020	6.90
					<u>65.15</u>
10-35-56-11100	GIFT SHOP - SALES TAX				
37271	ILLDEP ILLINOIS DEPT. OF REVENUE		26221	02/14/2020	80.00
					<u>80.00</u>
10-35-58-00800	ELECTRICITY				
37401	COMED COMED	20200223	26313	02/28/2020	1,056.07
					<u>1,056.07</u>
10-35-58-00830	WATER				
37735	VILLWAT VILLAGE OF OAK PARK-WATER WAI		508652	02/14/2020	186.50
					<u>186.50</u>
10-50-52-00260	PROPERTY REPAIR				
36997	ANDERSONE SOUTH WEST INDUSTRIES, INC.	20200113	26163	02/07/2020	165.00
37014	HEMSTR TERRENCE J. HEMSTREET	20200120	26179	02/07/2020	110.00

Park District of Oak Park

FY 2020

AP ACCOUNT DISTRIBUTION BY ACCOUNT OPEN & PAID VOUCHERS

CHECK DATES 02/01/2020 TO 02/29/2020 PAY DATES 02/01/2020 TO 02/29/2020

BOTH ACCRUALS AND NON ACCRUALS

CHECK RUN 0 TO 2147483647

<u>VOUCHER NUMBER</u>	<u>VENDOR</u>	<u>PO NUMBER</u>	<u>CHECK NUMBER</u>	<u>PAY DATE/ CHECK DATE</u>	<u>AMOUNT</u>
10-50-52-00260 PROPERTY REPAIR					
37023	OAKELE OAK ELECTRIC, INC.	20200121	26189	02/07/2020	316.00
37033	SPANNUTH SPANNUTH BOILER COMPANY	20200114	26197	02/07/2020	450.00 A
37038	WALTER WALTER DANIELS CONSTRUCTION	20200112	26202	02/07/2020	617.04 A
37281	PREMIERM PREMIER MECHANICAL INC	20200147	26231	02/14/2020	47,000.00
37312	BRENNANS CHRISTOPHER BRENNANS	20200177	26245	02/21/2020	375.00
37313	BRENNANS CHRISTOPHER BRENNANS	20200177	26245	02/21/2020	375.00
37314	BRENNANS CHRISTOPHER BRENNANS	20200177	26245	02/21/2020	175.00
37315	BRENNANS CHRISTOPHER BRENNANS	20200177	26245	02/21/2020	125.00
37321	EQUIP EQUIPMENT DEPOT OF ILLINOIS	20200173	26264	02/21/2020	255.92
37331	GLASSDES GLASS DESIGN, INC.	20200176	26268	02/21/2020	425.00
37343	OAKELE OAK ELECTRIC, INC.	20200178	26282	02/21/2020	1,275.00
37358	YOUNA YOUNA MECHANICAL INC	20200179	26298	02/21/2020	1,193.75
37359	YOUNA YOUNA MECHANICAL INC	20200181	26298	02/21/2020	5,972.25
37360	YOUNA YOUNA MECHANICAL INC	20200190	26298	02/21/2020	485.00
37375	ACCURATE ACCURATE FIRE EQUIPMENT CO.	20200239	26303	02/28/2020	67.00
37376	ACCURATE ACCURATE FIRE EQUIPMENT CO.	20200239	26303	02/28/2020	49.00
37377	ACCURATE ACCURATE FIRE EQUIPMENT CO.	20200239	26303	02/28/2020	49.00
37378	ACCURATE ACCURATE FIRE EQUIPMENT CO.	20200239	26303	02/28/2020	55.00
37379	ACCURATE ACCURATE FIRE EQUIPMENT CO.	20200239	26303	02/28/2020	46.00
37380	ACCURATE ACCURATE FIRE EQUIPMENT CO.	20200239	26303	02/28/2020	52.00
37381	ACCURATE ACCURATE FIRE EQUIPMENT CO.	20200239	26303	02/28/2020	52.00
37382	ACCURATE ACCURATE FIRE EQUIPMENT CO.	20200239	26303	02/28/2020	52.00
37383	ACCURATE ACCURATE FIRE EQUIPMENT CO.	20200239	26303	02/28/2020	55.00
37384	ACCURATE ACCURATE FIRE EQUIPMENT CO.	20200239	26303	02/28/2020	106.00
37385	ACCURATE ACCURATE FIRE EQUIPMENT CO.	20200239	26303	02/28/2020	98.00
37386	ACCURATE ACCURATE FIRE EQUIPMENT CO.	20200239	26303	02/28/2020	88.00
37387	ACCURATE ACCURATE FIRE EQUIPMENT CO.	20200239	26303	02/28/2020	52.00
37388	ACCURATE ACCURATE FIRE EQUIPMENT CO.	20200239	26303	02/28/2020	106.00
37389	ACCURATE ACCURATE FIRE EQUIPMENT CO.	20200239	26303	02/28/2020	64.00
37390	ACCURATE ACCURATE FIRE EQUIPMENT CO.	20200239	26303	02/28/2020	257.00
37393	ANDERSONE SOUTH WEST INDUSTRIES, INC.	20200241	26306	02/28/2020	165.00
37434	MCDONTIM TIM MCDONALD	20200236	26354	02/28/2020	440.00
37644	PELICAN PELICAN WIRELESS		508600	02/14/2020	15.00
					61,182.96
10-50-52-00265 FLEET SERVICE					
37000	ATLASBOB ATLAS BOBCAT OMPANIES	20200118	26165	02/07/2020	315.21 A
37032	SARROS JAMES SARROS	20200141	26196	02/07/2020	300.00
37450	VILFLE VILLAGE OF OAK PARK FLEET	20190417	26357	02/28/2020	1,885.83
37451	VILFLE VILLAGE OF OAK PARK FLEET	20190417	26358	02/28/2020	4,848.95
37452	VILFLE VILLAGE OF OAK PARK FLEET	20190417	26359	02/28/2020	7,464.66
					14,814.65
10-50-52-00275 CUSTODIAL SERVICES					
37260	CRYSTAL CRYSTAL MGMT & MAINTENANCE	20200148	26212	02/14/2020	4,455.00
37262	CRYSTAL CRYSTAL MGMT & MAINTENANCE	20200148	26213	02/14/2020	690.00
					5,145.00
10-50-52-00280 SCAVENGER SERVICE					
37040	WESTCOOK WEST COOK COUNTY SOLID WAS	20200137	26204	02/07/2020	740.56 A

Park District of Oak Park

FY 2020

AP ACCOUNT DISTRIBUTION BY ACCOUNT OPEN & PAID VOUCHERS

CHECK DATES 02/01/2020 TO 02/29/2020 PAY DATES 02/01/2020 TO 02/29/2020

BOTH ACCRUALS AND NON ACCRUALS

CHECK RUN 0 TO 2147483647

<u>VOUCHER NUMBER</u>	<u>VENDOR</u>	<u>PO NUMBER</u>	<u>CHECK NUMBER</u>	<u>PAY DATE/ CHECK DATE</u>	<u>AMOUNT</u>
					740.56
10-50-52-00286	SPORTS FIELD IMPROVEMENTS				
37307	A&L A & L GREAT LAKES LABORATORIES	20200170	26240	02/21/2020	556.03
					556.03
10-50-53-00301	UNIFORMS				
37357	WAREHOU WAREHOUSE DIRECT OFFICE	20200171	26297	02/21/2020	124.50
37531	AMAZ AMAZON.COM		508496	02/14/2020	99.93
37533	AMAZ AMAZON.COM		508496	02/14/2020	84.98
37612	LEONARD AM LEONARD		508571	02/14/2020	485.31
37666	SKECHERS SKECHERS-USA		508628	02/14/2020	83.99
					878.71
10-50-53-00310	SUPPLIES-PARKS				
37016	HOMER HOMER INDUSTRIES, LLC	20200139	26181	02/07/2020	480.00
37029	REIN REINDERS, INC	20200117	26194	02/07/2020	262.50
37030	REIN REINDERS, INC	20200117	26194	02/07/2020	190.45
37319	CONSER CONSERVE FS, INC.	20200174	26250	02/21/2020	2,590.00
37526	TELETRON TELETRON ACE HARDWARE		508640	02/14/2020	129.10
37531	AMAZ AMAZON.COM		508496	02/14/2020	28.83
37531	AMAZ AMAZON.COM		508496	02/14/2020	6.99
37531	AMAZ AMAZON.COM		508496	02/14/2020	-28.83
37531	AMAZ AMAZON.COM		508496	02/14/2020	8.70
37531	AMAZ AMAZON.COM		508496	02/14/2020	4.00
37531	AMAZ AMAZON.COM		508496	02/14/2020	4.86
37533	AMAZ AMAZON.COM		508496	02/14/2020	4.69
37533	AMAZ AMAZON.COM		508496	02/14/2020	64.89
37533	AMAZ AMAZON.COM		508496	02/14/2020	45.45
37533	AMAZ AMAZON.COM		508496	02/14/2020	160.39
37533	AMAZ AMAZON.COM		508496	02/14/2020	134.85
37533	AMAZ AMAZON.COM		508496	02/14/2020	32.99
37549	CONSERVAT CONSERVATION MART LLC		508513	02/14/2020	210.17
37574	GERMANIA GERMANIA SEED CO		508537	02/14/2020	73.54
37580	GRAINGER GRAINGER, INC.		508542	02/14/2020	140.34
37583	HOME HOME DEPOT		508547	02/14/2020	116.92
37584	HOME HOME DEPOT		508547	02/14/2020	91.79
37584	HOME HOME DEPOT		508547	02/14/2020	73.37
37584	HOME HOME DEPOT		508547	02/14/2020	115.03
37638	JPPARK JP PARK WAYSIDE		508563	02/14/2020	3.56
37638	JPPARK JP PARK WAYSIDE		508563	02/14/2020	57.05
37659	RUSSO RUSSO POWER EQUIPMENT		508622	02/14/2020	3.96
37659	RUSSO RUSSO POWER EQUIPMENT		508622	02/14/2020	19.56
37664	SIGNEXP SIGN EXPRESS		508627	02/14/2020	669.00
37687	USPS USPS-POSTMASTER		508647	02/14/2020	19.50
					5,713.65
10-50-53-00311	SUPPLIES- CLEANING & HOUSEHOLD				
37034	ULINE ULINE INC	20200115	26199	02/07/2020	1,746.42 A
37036	ULINE ULINE INC	20200138	26199	02/07/2020	419.13
37448	ULINE ULINE INC	20200243	26356	02/28/2020	654.56
37678	TARGET TARGET STORES, INC		508639	02/14/2020	9.98

Park District of Oak Park

FY 2020

AP ACCOUNT DISTRIBUTION BY ACCOUNT OPEN & PAID VOUCHERS

CHECK DATES 02/01/2020 TO 02/29/2020 PAY DATES 02/01/2020 TO 02/29/2020

BOTH ACCRUALS AND NON ACCRUALS

CHECK RUN 0 TO 2147483647

<u>VOUCHER NUMBER</u>	<u>VENDOR</u>	<u>PO NUMBER</u>	<u>CHECK NUMBER</u>	<u>PAY DATE/ CHECK DATE</u>	<u>AMOUNT</u>
					2,830.09
10-50-53-00313	SUPPLIES - BUILDING MATERIALS				
37035	ULINE ULINE INC	20200115	26199	02/07/2020	1,228.01 A
37531	AMAZ AMAZON.COM		508496	02/14/2020	159.20
37531	AMAZ AMAZON.COM		508496	02/14/2020	27.98
37531	AMAZ AMAZON.COM		508496	02/14/2020	156.00
37555	CVS CVS PHARMACY		508518	02/14/2020	10.49
37580	GRAINGER GRAINGER, INC.		508542	02/14/2020	52.55
37583	HOME HOME DEPOT		508547	02/14/2020	18.36
37583	HOME HOME DEPOT		508547	02/14/2020	49.66
37583	HOME HOME DEPOT		508547	02/14/2020	24.75
37583	HOME HOME DEPOT		508547	02/14/2020	139.52
37584	HOME HOME DEPOT		508547	02/14/2020	35.10
37584	HOME HOME DEPOT		508547	02/14/2020	245.70
37618	MCMASTER MCMASTER-CARR SUPPLY CO.		508577	02/14/2020	103.50
37661	SCHAU SCHAUER'S HARDWARE		508624	02/14/2020	25.60
37661	SCHAU SCHAUER'S HARDWARE		508624	02/14/2020	16.18
37661	SCHAU SCHAUER'S HARDWARE		508624	02/14/2020	50.21
37663	SHERWIN SHERWIN-WILLIAMS CO.		508626	02/14/2020	51.73
37667	SOUTH SOUTH SIDE CONTROL SUPPLY CO.		508629	02/14/2020	241.79
37667	SOUTH SOUTH SIDE CONTROL SUPPLY CO.		508629	02/14/2020	118.18
37667	SOUTH SOUTH SIDE CONTROL SUPPLY CO.		508629	02/14/2020	118.18
37667	SOUTH SOUTH SIDE CONTROL SUPPLY CO.		508629	02/14/2020	800.19
37667	SOUTH SOUTH SIDE CONTROL SUPPLY CO.		508629	02/14/2020	956.84
					4,629.72
10-50-53-00410	EQUIPMENT				
37028	REIN REINDERS, INC	20200117	26194	02/07/2020	3,063.14 A
37031	RUSSO RUSSO POWER EQUIPMENT	20200119	26195	02/07/2020	87.12
37342	NUTOYS NUTOYS LEISURE PRODUCTS	20200172	26281	02/21/2020	39.28
37533	AMAZ AMAZON.COM		508496	02/14/2020	160.96
37659	RUSSO RUSSO POWER EQUIPMENT		508622	02/14/2020	42.00
					3,392.50
10-50-56-00605	CONFERENCE AND TRAINING				
37669	PERDIEM PERDIEM		508611	02/14/2020	14.33
37681	PERDIEM PERDIEM		508611	02/14/2020	13.34
37681	PERDIEM PERDIEM		508611	02/14/2020	33.84
37681	PERDIEM PERDIEM		508611	02/14/2020	35.46
37738	PERDIEM PERDIEM		508611	02/14/2020	4.77
37738	PERDIEM PERDIEM		508611	02/14/2020	5.57
37738	PERDIEM PERDIEM		508611	02/14/2020	12.86
37739	HILTON HILTON		508544	02/14/2020	681.50
37745	HYATT HYATT HOTELS		508550	02/14/2020	186.65
37761	IPRA ILLINOIS PARKS & RECREATION ASSOCI		508559	02/14/2020	579.00
37763	PERDIEM PERDIEM		508611	02/14/2020	28.50
37763	PERDIEM PERDIEM		508611	02/14/2020	28.50
37763	PERDIEM PERDIEM		508611	02/14/2020	12.09
37765	PERDIEM PERDIEM		508611	02/14/2020	4.64
37765	PERDIEM PERDIEM		508611	02/14/2020	3.91

Park District of Oak Park

FY 2020

AP ACCOUNT DISTRIBUTION BY ACCOUNT OPEN & PAID VOUCHERS

CHECK DATES 02/01/2020 TO 02/29/2020 PAY DATES 02/01/2020 TO 02/29/2020

BOTH ACCRUALS AND NON ACCRUALS

CHECK RUN 0 TO 2147483647

<u>VOUCHER NUMBER</u>	<u>VENDOR</u>	<u>PO NUMBER</u>	<u>CHECK NUMBER</u>	<u>PAY DATE/ CHECK DATE</u>	<u>AMOUNT</u>
10-50-56-00605 CONFERENCE AND TRAINING					
37765	PERDIEM PERDIEM		508611	02/14/2020	86.76
37765	PERDIEM PERDIEM		508611	02/14/2020	5.89
37765	PERDIEM PERDIEM		508611	02/14/2020	5.89
37765	PERDIEM PERDIEM		508611	02/14/2020	3.74
37765	PERDIEM PERDIEM		508611	02/14/2020	10.15
37765	PERDIEM PERDIEM		508611	02/14/2020	11.43
37769	PDRMA PDRMA		508599	02/14/2020	15.00
37769	PDRMA PDRMA		508599	02/14/2020	30.00
37787	PERDIEM PERDIEM		508611	02/14/2020	65.50
37787	PERDIEM PERDIEM		508611	02/14/2020	14.44
37787	PERDIEM PERDIEM		508611	02/14/2020	64.71
37787	PERDIEM PERDIEM		508611	02/14/2020	9.78
37787	PERDIEM PERDIEM		508611	02/14/2020	13.97
37789	PERDIEM PERDIEM		508611	02/14/2020	26.44
					<u>2,008.66</u>
10-50-56-00610 DUES AND SUBSCRIPTIONS					
37595	ILLISEC ILLINOIS SECRETARY OF STATE		508552	02/14/2020	51.13
37600	ISA INTERNTNL SOC OF ARBORICULTURE		508556	02/14/2020	190.00
					<u>241.13</u>
10-50-58-00800 ELECTRICITY					
37400	COMED COMED	20200222	26312	02/28/2020	533.43
37401	COMED COMED	20200223	26313	02/28/2020	3,633.00
37402	COMED COMED	20200223	26317	02/28/2020	800.58
37403	COMED COMED	20200222	26318	02/28/2020	66.33
37404	COMED COMED	20200222	26319	02/28/2020	31.98
37405	COMED COMED	20200222	26320	02/28/2020	25.39
37407	COMED COMED	20200221	26322	02/28/2020	1,154.44
37408	COMED COMED	20200212	26323	02/28/2020	244.70
37409	COMED COMED	20200211	26324	02/28/2020	143.99
37410	COMED COMED	20200219	26314	02/28/2020	469.56
37413	COMED COMED	20200210	26316	02/28/2020	31.87
37415	COMED DELI COMED DELIVERY SERVICES	20200213	26326	02/28/2020	223.27
37431	HUDSON HUDSON ENERGY - IL	20200214	26337	02/28/2020	330.51
					<u>7,689.05</u>
10-50-58-00820 TELECOMMUNICATIONS					
37547	COMCAST COMCAST		508512	02/14/2020	108.35
					<u>108.35</u>
10-50-58-00830 WATER					
37702	VILLWAT VILLAGE OF OAK PARK-WATER WA1		508652	02/14/2020	10.00
37703	VILLWAT VILLAGE OF OAK PARK-WATER WA1		508652	02/14/2020	10.00
37704	VILLWAT VILLAGE OF OAK PARK-WATER WA1		508652	02/14/2020	10.00
37705	VILLWAT VILLAGE OF OAK PARK-WATER WA1		508652	02/14/2020	10.00
37706	VILLWAT VILLAGE OF OAK PARK-WATER WA1		508652	02/14/2020	10.00
37707	VILLWAT VILLAGE OF OAK PARK-WATER WA1		508652	02/14/2020	10.00
37708	VILLWAT VILLAGE OF OAK PARK-WATER WA1		508652	02/14/2020	10.00
37709	VILLWAT VILLAGE OF OAK PARK-WATER WA1		508652	02/14/2020	15.00
37710	VILLWAT VILLAGE OF OAK PARK-WATER WA1		508652	02/14/2020	15.00

Park District of Oak Park

FY 2020

AP ACCOUNT DISTRIBUTION BY ACCOUNT OPEN & PAID VOUCHERS

CHECK DATES 02/01/2020 TO 02/29/2020 PAY DATES 02/01/2020 TO 02/29/2020

BOTH ACCRUALS AND NON ACCRUALS

CHECK RUN 0 TO 2147483647

VOUCHER NUMBER	VENDOR	PO NUMBER	CHECK NUMBER	PAY DATE/ CHECK DATE	AMOUNT
10-50-58-00830 WATER					
37711	VILLWAT VILLAGE OF OAK PARK-WATER WA1		508652	02/14/2020	15.00
37712	VILLWAT VILLAGE OF OAK PARK-WATER WA1		508652	02/14/2020	15.00
37713	VILLWAT VILLAGE OF OAK PARK-WATER WA1		508652	02/14/2020	15.00
37714	VILLWAT VILLAGE OF OAK PARK-WATER WA1		508652	02/14/2020	15.00
37715	VILLWAT VILLAGE OF OAK PARK-WATER WA1		508652	02/14/2020	15.00
37716	VILLWAT VILLAGE OF OAK PARK-WATER WA1		508652	02/14/2020	15.00
37717	VILLWAT VILLAGE OF OAK PARK-WATER WA1		508652	02/14/2020	15.00
37718	VILLWAT VILLAGE OF OAK PARK-WATER WA1		508652	02/14/2020	15.00
37719	VILLWAT VILLAGE OF OAK PARK-WATER WA1		508652	02/14/2020	15.00
37720	VILLWAT VILLAGE OF OAK PARK-WATER WA1		508652	02/14/2020	15.00
37721	VILLWAT VILLAGE OF OAK PARK-WATER WA1		508652	02/14/2020	15.00
37722	VILLWAT VILLAGE OF OAK PARK-WATER WA1		508652	02/14/2020	25.00
37724	VILLWAT VILLAGE OF OAK PARK-WATER WA1		508652	02/14/2020	30.00
37725	VILLWAT VILLAGE OF OAK PARK-WATER WA1		508652	02/14/2020	39.50
37726	VILLWAT VILLAGE OF OAK PARK-WATER WA1		508652	02/14/2020	39.50
37727	VILLWAT VILLAGE OF OAK PARK-WATER WA1		508652	02/14/2020	51.75
37728	VILLWAT VILLAGE OF OAK PARK-WATER WA1		508652	02/14/2020	64.00
37729	VILLWAT VILLAGE OF OAK PARK-WATER WA1		508652	02/14/2020	72.12
37730	VILLWAT VILLAGE OF OAK PARK-WATER WA1		508652	02/14/2020	76.25
37731	VILLWAT VILLAGE OF OAK PARK-WATER WA1		508652	02/14/2020	76.25
37732	VILLWAT VILLAGE OF OAK PARK-WATER WA1		508652	02/14/2020	88.50
37733	VILLWAT VILLAGE OF OAK PARK-WATER WA1		508652	02/14/2020	88.50
37736	VILLWAT VILLAGE OF OAK PARK-WATER WA1		508652	02/14/2020	693.85
37737	VILLWAT VILLAGE OF OAK PARK-WATER WA1		508652	02/14/2020	762.83
					2,373.05
FUND 10 TOTAL					279,259.93
16 LIABILITY					
16-00-52-00510 WORKER'S COMP					
37042	PDRMA PDRMA	20191042	26193	02/07/2020	39,669.54 A
					39,669.54
16-00-52-00511 PROPERTY					
37042	PDRMA PDRMA	20191042	26193	02/07/2020	46,952.76 A
					46,952.76
16-00-52-00512 EMPLOYMENT PRACTICES					
37042	PDRMA PDRMA	20191042	26193	02/07/2020	7,457.76 A
					7,457.76
16-00-52-00513 LIABILITY					
37042	PDRMA PDRMA	20191042	26193	02/07/2020	22,279.50 A
					22,279.50
16-00-52-00514 EMPLOYEE SCREENINGS					
37025	OCCUPHEAL OCCUPATIONAL HEALTH CENTE	20200142	26191	02/07/2020	122.00
					122.00
16-00-53-00350 RISK CARE MANAGEMENT					
37440	PDRMA PDRMA	20200259	26346	02/28/2020	199.00
37530	ALICE ALICE TRAINING INSTITUTE, LLC		508492	02/14/2020	695.00
37530	ALICE ALICE TRAINING INSTITUTE, LLC		508492	02/14/2020	695.00

Park District of Oak Park

FY 2020

AP ACCOUNT DISTRIBUTION BY ACCOUNT OPEN & PAID VOUCHERS

CHECK DATES 02/01/2020 TO 02/29/2020 PAY DATES 02/01/2020 TO 02/29/2020

BOTH ACCRUALS AND NON ACCRUALS

CHECK RUN 0 TO 2147483647

VOUCHER NUMBER	VENDOR	PO NUMBER	CHECK NUMBER	PAY DATE/ CHECK DATE	AMOUNT
16-00-53-00350	RISK CARE MANAGEMENT				
37531	AMAZ AMAZON.COM		508496	02/14/2020	594.70
37531	AMAZ AMAZON.COM		508496	02/14/2020	21.98
37533	AMAZ AMAZON.COM		508496	02/14/2020	18.15
37662	SCHLHE SCHOOL HEALTH CORPORATION		508625	02/14/2020	124.23
					<u>2,348.06</u>
16-00-56-00605	CONFERENCE AND TRAINING				
37756	IAPD ILLINOIS ASSOCIATION OF PARK DISTRI		508551	02/14/2020	365.00
37760	PERDIEM PERDIEM		508611	02/14/2020	6.58
37760	PERDIEM PERDIEM		508611	02/14/2020	9.68
37760	PERDIEM PERDIEM		508611	02/14/2020	10.46
37760	PERDIEM PERDIEM		508611	02/14/2020	11.48
					<u>403.20</u>
16-00-56-00660	UNEMPLOYMENT EXPENSE				
37336	IDES I.D.E.S. ILL DEPT EMPLOYMENT SECURI20200195		26274	02/21/2020	7,028.00
					<u>7,028.00</u>
					<u>126,260.82</u>
FUND 16 TOTAL					
20 RECREATION					
20-00-21-20135	REFUNDS DUE				
37041	LYNK ERICKA LYNK		26185	02/07/2020	40.00
37291	DAYM MAYA DAY		26214	02/14/2020	734.00
37292	OHANNES LARRY OHANNES		26226	02/14/2020	90.00
37461	KILLOREN ANN KILLOREN		26339	02/28/2020	10.00
37462	WACHTEL DAVID WACHTEL		26360	02/28/2020	120.00
					<u>994.00</u>
20-00-52-00265	FLEET SERVICE				
37593	I-PASS I-PASS ILLINOIS TOLLWAY		508558	02/14/2020	40.00
					<u>40.00</u>
20-00-56-00605	CONFERENCE AND TRAINING				
37586	HYATT HYATT HOTELS		508550	02/14/2020	146.74
37587	HYATT HYATT HOTELS		508550	02/14/2020	146.74
37742	HYATT HYATT HOTELS		508550	02/14/2020	146.74
37744	HYATT HYATT HOTELS		508550	02/14/2020	146.74
37744	HYATT HYATT HOTELS		508550	02/14/2020	146.74
37747	HYATT HYATT HOTELS		508550	02/14/2020	146.74
37751	HYATT HYATT HOTELS		508550	02/14/2020	158.48
37752	IAPD ILLINOIS ASSOCIATION OF PARK DISTRI		508551	02/14/2020	55.00
37753	IAPD ILLINOIS ASSOCIATION OF PARK DISTRI		508551	02/14/2020	55.00
37754	IAPD ILLINOIS ASSOCIATION OF PARK DISTRI		508551	02/14/2020	65.00
37757	IAPD ILLINOIS ASSOCIATION OF PARK DISTRI		508551	02/14/2020	55.00
37762	PERDIEM PERDIEM		508611	02/14/2020	6.26
37762	PERDIEM PERDIEM		508611	02/14/2020	5.91
37762	PERDIEM PERDIEM		508611	02/14/2020	4.29
37762	PERDIEM PERDIEM		508611	02/14/2020	21.41
37762	PERDIEM PERDIEM		508611	02/14/2020	58.66
37764	PERDIEM PERDIEM		508611	02/14/2020	8.58
37764	PERDIEM PERDIEM		508611	02/14/2020	13.38

Park District of Oak Park

FY 2020

AP ACCOUNT DISTRIBUTION BY ACCOUNT OPEN & PAID VOUCHERS

CHECK DATES 02/01/2020 TO 02/29/2020 PAY DATES 02/01/2020 TO 02/29/2020

BOTH ACCRUALS AND NON ACCRUALS

CHECK RUN 0 TO 2147483647

<u>VOUCHER NUMBER</u>	<u>VENDOR</u>	<u>PO NUMBER</u>	<u>CHECK NUMBER</u>	<u>PAY DATE/ CHECK DATE</u>	<u>AMOUNT</u>
20-00-56-00605 CONFERENCE AND TRAINING					
37764	PERDIEM PERDIEM		508611	02/14/2020	10.23
37764	PERDIEM PERDIEM		508611	02/14/2020	14.63
37764	PERDIEM PERDIEM		508611	02/14/2020	10.62
37764	PERDIEM PERDIEM		508611	02/14/2020	12.68
37764	PERDIEM PERDIEM		508611	02/14/2020	6.75
37766	PERDIEM PERDIEM		508611	02/14/2020	3.35
37766	PERDIEM PERDIEM		508611	02/14/2020	70.00
37767	PERDIEM PERDIEM		508611	02/14/2020	8.93
37767	PERDIEM PERDIEM		508611	02/14/2020	26.91
37767	PERDIEM PERDIEM		508611	02/14/2020	23.56
37767	PERDIEM PERDIEM		508611	02/14/2020	10.00
37767	PERDIEM PERDIEM		508611	02/14/2020	84.00
37768	PERDIEM PERDIEM		508611	02/14/2020	4.65
37768	PERDIEM PERDIEM		508611	02/14/2020	84.00
37771	PDRMA PDRMA		508599	02/14/2020	35.00
37776	PERDIEM PERDIEM		508611	02/14/2020	18.83
37776	PERDIEM PERDIEM		508611	02/14/2020	18.83
37776	PERDIEM PERDIEM		508611	02/14/2020	18.83
37782	HYATT HYATT HOTELS		508550	02/14/2020	293.48
37792	PERDIEM PERDIEM		508611	02/14/2020	6.92
37792	PERDIEM PERDIEM		508611	02/14/2020	8.66
37792	PERDIEM PERDIEM		508611	02/14/2020	31.38
					<u>2,189.65</u>
20-00-56-00610 DUES AND SUBSCRIPTIONS					
36996	AMBROSE MICHAEL AMBROSE	20200136	26162	02/07/2020	100.00
37758	IPRA ILLINOIS PARKS & RECREATION ASSOCI		508559	02/14/2020	279.00
					<u>379.00</u>
20-00-56-00615 EMPLOYEE TRAVEL REIMBURSEMENT					
37018	LOSZACH MIKE LOSZACH		26184	02/07/2020	12.53
37332	GROOMS BARBARA GROOMS		26269	02/21/2020	26.45
37339	LANDAU AILEEN LANDAU		26277	02/21/2020	22.14
37340	LILLY JOSEPH LILLY		26278	02/21/2020	36.27
					<u>97.39</u>
20-00-56-09999 NON-RESIDENT FEE EXPENSE					
37445	RIVERPARK RIVER FOREST PARK DISTRICT	20200208	26351	02/28/2020	275.00
					<u>275.00</u>
20-00-58-00820 TELECOMMUNICATIONS					
37397	CALLONE CALLONE	20200227	26309	02/28/2020	6,443.25
37398	CALLONE CALLONE	20200227	26310	02/28/2020	7,208.71
					<u>13,651.96</u>
20-05-52-00209 Copying and Printing - External					
36994	ABCBUS ABC PRINTING COMPANY	20200133	26159	02/07/2020	532.18
37009	FORPRI FOREST PRINTING CO. INC.	20190256	26175	02/07/2020	2,423.87 A
37010	FORPRI FOREST PRINTING CO. INC.	20191683	26175	02/07/2020	2,423.87
					<u>5,379.92</u>
20-05-52-00221 Brochure					
37317	CHICLAND CHICAGOLAND CIRCULATION SEI	20200196	26248	02/21/2020	4,500.00

Park District of Oak Park

FY 2020

AP ACCOUNT DISTRIBUTION BY ACCOUNT OPEN & PAID VOUCHERS

CHECK DATES 02/01/2020 TO 02/29/2020 PAY DATES 02/01/2020 TO 02/29/2020

BOTH ACCRUALS AND NON ACCRUALS

CHECK RUN 0 TO 2147483647

<u>VOUCHER NUMBER</u>	<u>VENDOR</u>	<u>PO NUMBER</u>	<u>CHECK NUMBER</u>	<u>PAY DATE/ CHECK DATE</u>	<u>AMOUNT</u>
20-05-52-00221	Brochure				
37341	MORRIS NANCY J. MORRIS N2 STUDIOS	20200188	26279	02/21/2020	4,740.00
37682	UBERFLIP UBERFLIP		508645	02/14/2020	10.00
37682	UBERFLIP UBERFLIP		508645	02/14/2020	10.00
37682	UBERFLIP UBERFLIP		508645	02/14/2020	10.00
37682	UBERFLIP UBERFLIP		508645	02/14/2020	10.00
37682	UBERFLIP UBERFLIP		508645	02/14/2020	19.95
					<u>9,299.95</u>
20-05-56-00222	Marketing				
37253	ABCBUS ABC PRINTING COMPANY	20200160	26206	02/14/2020	334.42
37542	CAPSULE CAPSULCRM.COM ZESTIA		508507	02/14/2020	36.00
37565	FACEBOOK FACEBOOK		508528	02/14/2020	287.46
37565	FACEBOOK FACEBOOK		508528	02/14/2020	748.74
37566	TRT TRT BANNERS, LLC		508644	02/14/2020	592.79
37569	FEDEX FEDEX		508531	02/14/2020	30.41
37604	JEWELS JEWEL - OSCO		508562	02/14/2020	30.83
37690	PARKING PARKING		508597	02/14/2020	2.00
					<u>2,062.65</u>
20-05-56-00225	Advertising				
37039	WEDNES WEDNESDAY JOURNAL	20191440	26203	02/07/2020	425.00 A
					<u>425.00</u>
20-05-56-00605	Conference and Training				
37746	HYATT HYATT HOTELS		508550	02/14/2020	146.74
37772	HYATT HYATT HOTELS		508550	02/14/2020	219.74
37773	PERDIEM PERDIEM		508611	02/14/2020	6.71
37773	PERDIEM PERDIEM		508611	02/14/2020	21.00
37773	PERDIEM PERDIEM		508611	02/14/2020	10.72
37773	PERDIEM PERDIEM		508611	02/14/2020	3.07
37788	PERDIEM PERDIEM		508611	02/14/2020	23.29
37788	PERDIEM PERDIEM		508611	02/14/2020	21.97
37788	PERDIEM PERDIEM		508611	02/14/2020	10.67
37788	PERDIEM PERDIEM		508611	02/14/2020	6.71
					<u>470.62</u>
20-25-52-13050	FITNESS EXERCISE				
37268	FITNESSME THE FITNESS MECHANIC INC.	20200168	26218	02/14/2020	400.00
37613	LESMILLS LES MILLS UNITED STATES TRADI		508572	02/14/2020	248.00
					<u>648.00</u>
20-25-53-13050	FITNESS EXERCISE				
37525	2XLCORP 2XL CORPORATION GYMWIPES		508489	02/14/2020	179.70
37532	AMAZ AMAZON.COM		508496	02/14/2020	23.97
					<u>203.67</u>
20-26-52-13750	YOUTH SPORTS LEAGUES				
37280	PANEK BRIAN W. PANEK	20200156	26230	02/14/2020	4,063.00
					<u>4,063.00</u>
20-26-52-13870	YOUTH SPORTS CLINICS				
37361	YOUTH YOUTH ELITE SOCCER, LLC	20200189	26299	02/21/2020	826.50
					<u>826.50</u>
20-26-53-13750	YOUTH SPORTS LEAGUES				

Park District of Oak Park

FY 2020

AP ACCOUNT DISTRIBUTION BY ACCOUNT OPEN & PAID VOUCHERS

CHECK DATES 02/01/2020 TO 02/29/2020 PAY DATES 02/01/2020 TO 02/29/2020

BOTH ACCRUALS AND NON ACCRUALS

CHECK RUN 0 TO 2147483647

<u>VOUCHER NUMBER</u>	<u>VENDOR</u>	<u>PO NUMBER</u>	<u>CHECK NUMBER</u>	<u>PAY DATE/ CHECK DATE</u>	<u>AMOUNT</u>
20-26-53-13750	YOUTH SPORTS LEAGUES				
37256	AMERSOCC AMERICAN SOCCER COMPANY I	20200163	26208	02/14/2020	99.92
					<u>99.92</u>
20-29-52-13270	TEEN TRIPS				
37562	ENCHANT ENCHANTED CASTLE		508526	02/14/2020	202.50
37616	MAIN MAIN EVENT ENTERTAINMENT, LP		508574	02/14/2020	55.00
37616	MAIN MAIN EVENT ENTERTAINMENT, LP		508574	02/14/2020	118.72
37616	MAIN MAIN EVENT ENTERTAINMENT, LP		508574	02/14/2020	151.66
37695	WILMOT WILMOT MOUNTAIN		508658	02/14/2020	555.00
37695	WILMOT WILMOT MOUNTAIN		508658	02/14/2020	-18.00
					<u>1,064.88</u>
20-29-53-13270	TEEN TRIPS				
37695	WILMOT WILMOT MOUNTAIN		508658	02/14/2020	10.55
37695	WILMOT WILMOT MOUNTAIN		508658	02/14/2020	18.46
					<u>29.01</u>
20-29-53-13280	TEEN CLASSES				
37660	SALER SALERNO'S PIZZA		508623	02/14/2020	67.90
					<u>67.90</u>
20-51-53-00300	OFFICE EXPENSE				
37673	STAPLES STAPLES BUSINESS ADVANTAGE DE		508633	02/14/2020	38.51
					<u>38.51</u>
20-51-56-00600	EMPLOYEE RECOGNITION				
37604	JEWELS JEWEL - OSCO		508562	02/14/2020	11.27
37677	TACO TACO BROS		508638	02/14/2020	19.78
					<u>31.05</u>
20-51-56-00605	CONFERENCE AND TRAINING				
37749	HYATT HYATT HOTELS		508550	02/14/2020	146.74
37790	PERDIEM PERDIEM		508611	02/14/2020	12.77
37790	PERDIEM PERDIEM		508611	02/14/2020	10.44
37790	PERDIEM PERDIEM		508611	02/14/2020	10.06
37790	PERDIEM PERDIEM		508611	02/14/2020	6.98
					<u>186.99</u>
20-51-56-00610	DUES AND SUBSCRIPTIONS				
37759	IPRA ILLINOIS PARKS & RECREATION ASSOCI		508559	02/14/2020	279.00
					<u>279.00</u>
20-51-56-00615	EMPLOYEE TRAVEL REIMBURSEMENT				
37284	SEKULICH SCOTT SEKULICH		26234	02/14/2020	13.97
					<u>13.97</u>
20-61-52-12000	FRANK LLOYD WRIGHT RACE				
37024	OAKRIV OAK PARK-RIVER FOREST HIGH SCH	20200123	26190	02/07/2020	2,007.00 A
					<u>2,007.00</u>
20-61-52-12010	COMMUNITY SPECIAL EVENTS				
37396	ASCAP ASCAP LICENSE FEE	20200230	26308	02/28/2020	725.00
					<u>725.00</u>
20-61-52-12020	FAMILY EVENTS				
37568	FAIRY FAIRYTALE ENTERTAINMENT		508530	02/14/2020	237.00
					<u>237.00</u>

Park District of Oak Park

FY 2020

AP ACCOUNT DISTRIBUTION BY ACCOUNT OPEN & PAID VOUCHERS

CHECK DATES 02/01/2020 TO 02/29/2020 PAY DATES 02/01/2020 TO 02/29/2020

BOTH ACCRUALS AND NON ACCRUALS

CHECK RUN 0 TO 2147483647

<u>VOUCHER NUMBER</u>	<u>VENDOR</u>	<u>PO NUMBER</u>	<u>CHECK NUMBER</u>	<u>PAY DATE/ CHECK DATE</u>	<u>AMOUNT</u>
20-61-52-12030 COMMUNITY DAY CAMPS					
37322	FIRSTSTUD FIRST STUDENT, INC	20200185	26265	02/21/2020	250.00
37323	FIRSTSTUD FIRST STUDENT, INC	20200185	26265	02/21/2020	250.00
37324	FIRSTSTUD FIRST STUDENT, INC	20200185	26265	02/21/2020	250.00
37325	FIRSTSTUD FIRST STUDENT, INC	20200185	26265	02/21/2020	250.00
37326	FIRSTSTUD FIRST STUDENT, INC	20200185	26265	02/21/2020	250.00
37327	FIRSTSTUD FIRST STUDENT, INC	20200185	26265	02/21/2020	250.00
37328	FIRSTSTUD FIRST STUDENT, INC	20200185	26265	02/21/2020	521.10
37656	REPTILES TRAVELING REPTILES		508619	02/14/2020	300.00
					2,321.10
20-61-52-12050 ACTIVE ADULTS PROGRAMS					
37641	PARKING PARKING		508597	02/14/2020	8.63
37641	PARKING PARKING		508597	02/14/2020	9.91
					18.54
20-61-52-12340 SPECIAL INTEREST PROGRAMS					
37002	CHESS FAMBRO MANAGEMENT LLC	20200144	26168	02/07/2020	420.00
37273	KANT GARY KANTOR MAGIC OF GARY KANT	20200158	26223	02/14/2020	196.00
					616.00
20-61-53-12000 FRANK LLOYD WRIGHT RACE					
37275	OAKRIV OAK PARK-RIVER FOREST HIGH SCH	20200186	26225	02/14/2020	2,555.00
					2,555.00
20-61-53-12020 FAMILY EVENTS					
37532	AMAZ AMAZON.COM		508496	02/14/2020	93.27
37603	JEWELS JEWEL - OSCO		508562	02/14/2020	29.41
37642	PARCI PARTY CITY		508598	02/14/2020	172.74
37648	PETESFR PETE'S FRESH MARKET ROOSEVELT		508613	02/14/2020	18.36
					313.78
20-61-53-12040 AFTERSCHOOL PROGRAMS					
37529	ALDI ALDI STORE		508491	02/14/2020	7.32
37532	AMAZ AMAZON.COM		508496	02/14/2020	116.99
37551	COSTCO COSTCO		508514	02/14/2020	1,546.51
37555	CVS CVS PHARMACY		508518	02/14/2020	16.03
37558	DOLL DOLLARTREE		508522	02/14/2020	18.00
37558	DOLL DOLLARTREE		508522	02/14/2020	36.00
37559	DOLL DOLLARTREE		508522	02/14/2020	30.00
37559	DOLL DOLLARTREE		508522	02/14/2020	9.00
37559	DOLL DOLLARTREE		508522	02/14/2020	13.00
37559	DOLL DOLLARTREE		508522	02/14/2020	5.60
37560	DUNKIN DUNKIN DONUTS		508523	02/14/2020	18.48
37560	DUNKIN DUNKIN DONUTS		508523	02/14/2020	11.98
37567	FAIR FAIR SHARE FOODS		508529	02/14/2020	21.80
37579	GPTETREV GP TETREV POTTERY		508541	02/14/2020	25.00
37603	JEWELS JEWEL - OSCO		508562	02/14/2020	32.64
37603	JEWELS JEWEL - OSCO		508562	02/14/2020	44.38
37604	JEWELS JEWEL - OSCO		508562	02/14/2020	21.94
37604	JEWELS JEWEL - OSCO		508562	02/14/2020	15.06
37604	JEWELS JEWEL - OSCO		508562	02/14/2020	39.79
37604	JEWELS JEWEL - OSCO		508562	02/14/2020	10.47

Park District of Oak Park

FY 2020

AP ACCOUNT DISTRIBUTION BY ACCOUNT OPEN & PAID VOUCHERS

CHECK DATES 02/01/2020 TO 02/29/2020 PAY DATES 02/01/2020 TO 02/29/2020

BOTH ACCRUALS AND NON ACCRUALS

CHECK RUN 0 TO 2147483647

<u>VOUCHER NUMBER</u>	<u>VENDOR</u>	<u>PO NUMBER</u>	<u>CHECK NUMBER</u>	<u>PAY DATE/ CHECK DATE</u>	<u>AMOUNT</u>
20-61-53-12040 AFTERSCHOOL PROGRAMS					
37604	JEWELS JEWEL - OSCO		508562	02/14/2020	23.31
37604	JEWELS JEWEL - OSCO		508562	02/14/2020	87.64
37620	MICH MICHAELS STORE		508579	02/14/2020	37.82
37620	MICH MICHAELS STORE		508579	02/14/2020	67.23
37620	MICH MICHAELS STORE		508579	02/14/2020	116.24
37628	NAYAX NAYAX COPY SERVICES		508587	02/14/2020	4.50
37628	NAYAX NAYAX COPY SERVICES		508587	02/14/2020	0.15
37628	NAYAX NAYAX COPY SERVICES		508587	02/14/2020	9.00
37633	OFFDEP OFFICE DEPOT		508591	02/14/2020	33.37
37637	PAPERSOU PAPER SOURCE INC.		508596	02/14/2020	13.50
37639	PARKING PARKING		508597	02/14/2020	3.00
37648	PETESFR PETE'S FRESH MARKET ROOSEVELT		508613	02/14/2020	5.98
37648	PETESFR PETE'S FRESH MARKET ROOSEVELT		508613	02/14/2020	6.00
37648	PETESFR PETE'S FRESH MARKET ROOSEVELT		508613	02/14/2020	4.77
37648	PETESFR PETE'S FRESH MARKET ROOSEVELT		508613	02/14/2020	16.95
37648	PETESFR PETE'S FRESH MARKET ROOSEVELT		508613	02/14/2020	7.34
37648	PETESFR PETE'S FRESH MARKET ROOSEVELT		508613	02/14/2020	11.96
37648	PETESFR PETE'S FRESH MARKET ROOSEVELT		508613	02/14/2020	23.83
37648	PETESFR PETE'S FRESH MARKET ROOSEVELT		508613	02/14/2020	15.99
37648	PETESFR PETE'S FRESH MARKET ROOSEVELT		508613	02/14/2020	4.08
37660	SALER SALERNO'S PIZZA		508623	02/14/2020	54.70
37660	SALER SALERNO'S PIZZA		508623	02/14/2020	58.54
37678	TARGET TARGET STORES, INC		508639	02/14/2020	47.22
37678	TARGET TARGET STORES, INC		508639	02/14/2020	30.48
37678	TARGET TARGET STORES, INC		508639	02/14/2020	11.31
37678	TARGET TARGET STORES, INC		508639	02/14/2020	23.36
37678	TARGET TARGET STORES, INC		508639	02/14/2020	61.35
37678	TARGET TARGET STORES, INC		508639	02/14/2020	13.18
37678	TARGET TARGET STORES, INC		508639	02/14/2020	8.39
37678	TARGET TARGET STORES, INC		508639	02/14/2020	12.24
37678	TARGET TARGET STORES, INC		508639	02/14/2020	18.94
37691	WALG WALGREENS CO.		508653	02/14/2020	106.63
37691	WALG WALGREENS CO.		508653	02/14/2020	33.05
37691	WALG WALGREENS CO.		508653	02/14/2020	6.47
37692	WALMART WALMART STORES, INC.		508655	02/14/2020	9.88
37692	WALMART WALMART STORES, INC.		508655	02/14/2020	88.21
37695	WILMOT WILMOT MOUNTAIN		508658	02/14/2020	14.77
					3,131.37
20-61-53-12050 ACTIVE ADULTS PROGRAMS					
37351	SCHMUCKER HELEN SCHMUCKER		26290	02/21/2020	30.23
37447	TURNER MELODY TURNER		26355	02/28/2020	257.50
37558	DOLL DOLLARTREE		508522	02/14/2020	7.00
37559	DOLL DOLLARTREE		508522	02/14/2020	9.00
37575	GORDON GORDON FOOD SERVICES		508540	02/14/2020	189.03
37675	STAR STARSHIP CATERING		508635	02/14/2020	202.70
					695.46
20-61-53-12350 NATURE AND ADVENTURE PROGRAMS					

Park District of Oak Park

FY 2020

AP ACCOUNT DISTRIBUTION BY ACCOUNT OPEN & PAID VOUCHERS

CHECK DATES 02/01/2020 TO 02/29/2020 PAY DATES 02/01/2020 TO 02/29/2020

BOTH ACCRUALS AND NON ACCRUALS

CHECK RUN 0 TO 2147483647

<u>VOUCHER NUMBER</u>	<u>VENDOR</u>	<u>PO NUMBER</u>	<u>CHECK NUMBER</u>	<u>PAY DATE/ CHECK DATE</u>	<u>AMOUNT</u>
20-61-53-12350	NATURE AND ADVENTURE PROGRAMS				
37532	AMAZ AMAZON.COM		508496	02/14/2020	37.95
					<u>37.95</u>
20-61-53-12360	NATURE AND ADVENTURE CAMPS				
37648	PETESFR PETE'S FRESH MARKET ROOSEVELT		508613	02/14/2020	14.53
					<u>14.53</u>
20-62-52-12450	CERAMICS				
37003	CHGOKILN CHICAGO KILN SERVICE	20200145	26169	02/07/2020	235.00
					<u>235.00</u>
20-62-52-12610	DANCE PROGRAMS				
37352	TULLY CATHERINE TULLY	20200201	26292	02/21/2020	836.64
37417	DUVALL WILLIAM DUVALL	20200258	26328	02/28/2020	460.80
37459	ZEEMAN TERRY ZEEMAN	20200235	26364	02/28/2020	1,306.80
					<u>2,604.24</u>
20-62-53-12390	SCAW WORKSHOP				
37446	SKINNER ALEXANDRA SKINNER		26352	02/28/2020	35.94
37544	CERAM CERAMIC SUPPLY CHICAGO		508509	02/14/2020	291.60
37544	CERAM CERAMIC SUPPLY CHICAGO		508509	02/14/2020	645.15
37556	BLICK BLICK ART MATERIALS		508504	02/14/2020	49.13
37658	RIOGRAND RIO GRANDE INC.		508621	02/14/2020	58.94
37692	WALMART WALMART STORES, INC.		508655	02/14/2020	82.13
37692	WALMART WALMART STORES, INC.		508655	02/14/2020	-12.27
					<u>1,150.62</u>
20-62-53-12610	DANCE PROGRAMS				
37532	AMAZ AMAZON.COM		508496	02/14/2020	43.41
37532	AMAZ AMAZON.COM		508496	02/14/2020	32.97
37642	PARCI PARTY CITY		508598	02/14/2020	5.97
37642	PARCI PARTY CITY		508598	02/14/2020	7.84
37642	PARCI PARTY CITY		508598	02/14/2020	39.60
37643	TONYSFINE TONY'S FRESH MARKET		508642	02/14/2020	25.98
37660	SALER SALERNO'S PIZZA		508623	02/14/2020	39.50
37679	TONYSFINE TONY'S FRESH MARKET		508642	02/14/2020	42.75
					<u>238.02</u>
20-63-53-12700	PRESCHOOL				
37338	JOHNSONJ JORDYN JOHNSON		26276	02/21/2020	17.10
37529	ALDI ALDI STORE		508491	02/14/2020	9.72
37529	ALDI ALDI STORE		508491	02/14/2020	16.27
37532	AMAZ AMAZON.COM		508496	02/14/2020	31.13
37533	AMAZ AMAZON.COM		508496	02/14/2020	9.55
37557	DISCOUNT DISCOUNT SCHOOL SUPPLY		508520	02/14/2020	163.14
37558	DOLL DOLLARTREE		508522	02/14/2020	2.00
37558	DOLL DOLLARTREE		508522	02/14/2020	2.00
37558	DOLL DOLLARTREE		508522	02/14/2020	22.72
37559	DOLL DOLLARTREE		508522	02/14/2020	8.00
37559	DOLL DOLLARTREE		508522	02/14/2020	14.50
37571	FRESHTHY FRESH THYME		508534	02/14/2020	3.07
37603	JEWELS JEWEL - OSCO		508562	02/14/2020	8.98
37603	JEWELS JEWEL - OSCO		508562	02/14/2020	35.31

Park District of Oak Park

FY 2020

AP ACCOUNT DISTRIBUTION BY ACCOUNT OPEN & PAID VOUCHERS

CHECK DATES 02/01/2020 TO 02/29/2020 PAY DATES 02/01/2020 TO 02/29/2020

BOTH ACCRUALS AND NON ACCRUALS

CHECK RUN 0 TO 2147483647

VOUCHER NUMBER	VENDOR	PO NUMBER	CHECK NUMBER	PAY DATE/ CHECK DATE	AMOUNT
20-63-53-12700 PRESCHOOL					
37605	KAPLAN KAPLAN EARLY LEARNING COMPAN		508564	02/14/2020	175.90
37609	LAKESH LAKESHORE LEARNING		508568	02/14/2020	163.36
37635	OTCBRANDS OTC BRANDS INC		508594	02/14/2020	22.06
37635	OTCBRANDS OTC BRANDS INC		508594	02/14/2020	6.66
37648	PETESFR PETE'S FRESH MARKET ROOSEVELT		508613	02/14/2020	11.33
37653	QUILL GEORGE E. QUILL & SONS INC		508617	02/14/2020	47.72
37678	TARGET TARGET STORES, INC		508639	02/14/2020	41.49
37680	TRADER TRADER JOES		508643	02/14/2020	8.68
37680	TRADER TRADER JOES		508643	02/14/2020	40.40
37691	WALG WALGREENS CO.		508653	02/14/2020	1.57
37692	WALMART WALMART STORES, INC.		508655	02/14/2020	16.54
37692	WALMART WALMART STORES, INC.		508655	02/14/2020	54.00
37692	WALMART WALMART STORES, INC.		508655	02/14/2020	54.00
37692	WALMART WALMART STORES, INC.		508655	02/14/2020	4.81
37692	WALMART WALMART STORES, INC.		508655	02/14/2020	46.21
37692	WALMART WALMART STORES, INC.		508655	02/14/2020	26.61
37692	WALMART WALMART STORES, INC.		508655	02/14/2020	174.40
					<u>1,239.23</u>
20-63-53-12720 PLAYSCHOOL					
37529	ALDI ALDI STORE		508491	02/14/2020	26.57
37529	ALDI ALDI STORE		508491	02/14/2020	37.88
37529	ALDI ALDI STORE		508491	02/14/2020	35.52
37529	ALDI ALDI STORE		508491	02/14/2020	59.89
37558	DOLL DOLLARTREE		508522	02/14/2020	10.07
37620	MICH MICHAELS STORE		508579	02/14/2020	13.97
37692	WALMART WALMART STORES, INC.		508655	02/14/2020	38.07
					<u>221.97</u>
20-63-53-12740 EARLY CHILDHOOD CLASSES					
37692	WALMART WALMART STORES, INC.		508655	02/14/2020	29.99
					<u>29.99</u>
20-63-53-12840 INDOOR PLAYGROUND					
37603	JEWELS JEWEL - OSCO		508562	02/14/2020	3.50
37660	SALER SALERNO'S PIZZA		508623	02/14/2020	43.18
					<u>46.68</u>
					<u>61,256.02</u>
FUND 20 TOTAL					
21 MUSEUM					
21-00-52-00260 PROPERTY REPAIR					
37315	BRENNANS CHRISTOPHER BRENNANS	20200177	26245	02/21/2020	125.00
					<u>125.00</u>
21-00-58-00800 ELECTRICITY					
37401	COMED COMED	20200223	26313	02/28/2020	335.86
					<u>335.86</u>
21-00-58-00830 WATER					
37723	VILLWAT VILLAGE OF OAK PARK-WATER WAI		508652	02/14/2020	27.25
					<u>27.25</u>
					<u>488.11</u>
FUND 21 TOTAL					

Park District of Oak Park

FY 2020

AP ACCOUNT DISTRIBUTION BY ACCOUNT OPEN & PAID VOUCHERS

CHECK DATES 02/01/2020 TO 02/29/2020 PAY DATES 02/01/2020 TO 02/29/2020

BOTH ACCRUALS AND NON ACCRUALS

CHECK RUN 0 TO 2147483647

VOUCHER NUMBER	VENDOR	PO NUMBER	CHECK NUMBER	PAY DATE/ CHECK DATE	AMOUNT
25 SPECIAL FACILITIES					
25-00-56-00605 Conference and Training					
37008	FAURIA KAYLA FAURIA		26174	02/07/2020	146.74
37591	IPRA ILLINOIS PARKS & RECREATION ASSOCI		508559	02/14/2020	69.75
37740	PERDIEM PERDIEM		508611	02/14/2020	13.08
37740	PERDIEM PERDIEM		508611	02/14/2020	13.08
37748	HYATT HYATT HOTELS		508550	02/14/2020	146.74
37770	PDRMA PDRMA		508599	02/14/2020	35.00
37783	HYATT HYATT HOTELS		508550	02/14/2020	293.48
37783	HYATT HYATT HOTELS		508550	02/14/2020	-146.74
37784	PERDIEM PERDIEM		508611	02/14/2020	3.07
37789	PERDIEM PERDIEM		508611	02/14/2020	26.44
37789	PERDIEM PERDIEM		508611	02/14/2020	26.44
37789	PERDIEM PERDIEM		508611	02/14/2020	26.45
37793	PERDIEM PERDIEM		508611	02/14/2020	12.04
37793	PERDIEM PERDIEM		508611	02/14/2020	65.50
37797	PERDIEM PERDIEM		508611	02/14/2020	47.50
					<u>778.57</u>
25-00-56-00610 DUES AND SUBSCRIPTIONS					
37337	IPRA ILLINOIS PARKS & RECREATION ASSOCI	20200197	26275	02/21/2020	90.00
					<u>90.00</u>
25-00-58-00820 TELECOMMUNICATIONS					
37546	COMCAST COMCAST		508512	02/14/2020	143.35
37548	COMCAST COMCAST		508512	02/14/2020	113.35
					<u>256.70</u>
25-19-52-00259 GUARD TRAINING & EVALUATION					
37601	ELLIS J. ELLIS & ASSOCIATES, INC.		508525	02/14/2020	325.00
					<u>325.00</u>
25-19-52-00650 BANK SERVICE CHARGE					
37607	KEYROLL KEY LOG ROLLING		508566	02/14/2020	1,550.00
					<u>1,550.00</u>
25-19-52-11600 LEARN TO SWIM					
37674	STARFISH STARFISH AQUATICS INSTITUTE, L		508634	02/14/2020	6,348.00
					<u>6,348.00</u>
25-19-53-00301 UNIFORMS					
37277	ORIGINAL ORIGINAL WATERMEN INC.	20200153	26228	02/14/2020	4,767.75
37278	ORIGINAL ORIGINAL WATERMEN INC.	20200152	26228	02/14/2020	467.76
37435	M&MSPORTS M&M SPORTS SCENE INC.	20200255	26341	02/28/2020	3,079.80
37439	ORIGINAL ORIGINAL WATERMEN INC.	20200253	26345	02/28/2020	56.00
					<u>8,371.31</u>
25-19-53-00318 GUARD EQUIPMENT AND SUPPLIES					
37277	ORIGINAL ORIGINAL WATERMEN INC.	20200153	26228	02/14/2020	373.00
37532	AMAZ AMAZON.COM		508496	02/14/2020	182.44
37532	AMAZ AMAZON.COM		508496	02/14/2020	245.00
37614	LIFGUA LIFEGUARD STORE, INC.		508573	02/14/2020	26.91
37614	LIFGUA LIFEGUARD STORE, INC.		508573	02/14/2020	3,187.73
37614	LIFGUA LIFEGUARD STORE, INC.		508573	02/14/2020	92.00
37693	WATSAF WATER SAFETY PRODUCTS, INC.		508656	02/14/2020	151.40

Park District of Oak Park

FY 2020

AP ACCOUNT DISTRIBUTION BY ACCOUNT OPEN & PAID VOUCHERS

CHECK DATES 02/01/2020 TO 02/29/2020 PAY DATES 02/01/2020 TO 02/29/2020

BOTH ACCRUALS AND NON ACCRUALS

CHECK RUN 0 TO 2147483647

<u>VOUCHER NUMBER</u>	<u>VENDOR</u>	<u>PO NUMBER</u>	<u>CHECK NUMBER</u>	<u>PAY DATE/ CHECK DATE</u>	<u>AMOUNT</u>
					4,258.48
25-19-53-00320	MISCELLANEOUS SUPPLIES				
37692	WALMART WALMART STORES, INC.		508655	02/14/2020	176.36
37697	WRISTBAND WRISTBANDS.COM		508659	02/14/2020	391.60
					567.96
25-19-53-00400	EQUIPMENT - OFFICE				
37532	AMAZ AMAZON.COM		508496	02/14/2020	24.96
					24.96
25-19-53-11620	AQUATICS SPECIAL EVENTS				
37607	KEYROLL KEY LOG ROLLING		508566	02/14/2020	2,350.00
					2,350.00
25-20-52-11950	LEARN TO SKATE				
37686	AMERSPEC AMERICAN SPECIALTY INSURANC		508499	02/14/2020	100.00
					100.00
25-20-52-11960	YOUTH HOCKEY				
37392	AHAOFF AHAI OFFICIATING COMMITTEE	20200251	26305	02/28/2020	304.00
					304.00
25-20-52-11980	RINK SPECIAL EVENTS				
37347	PELL FRANK PELLICO	20200199	26287	02/21/2020	500.00
					500.00
25-20-53-00320	MISCELLANEOUS SUPPLIES				
37532	AMAZ AMAZON.COM		508496	02/14/2020	34.45
37559	DOLL DOLLARTREE		508522	02/14/2020	12.00
					46.45
25-20-53-11950	LEARN TO SKATE				
37540	BOATHOUSE BOATHOUSE SPORTS		508505	02/14/2020	1,697.30
					1,697.30
25-20-53-11960	YOUTH HOCKEY				
37652	PUREHOCK PURE HOCKEY.COM		508616	02/14/2020	249.96
					249.96
25-20-53-11980	RINK SPECIAL EVENTS				
37353	ULINE ULINE INC	20200135	26293	02/21/2020	461.62
37532	AMAZ AMAZON.COM		508496	02/14/2020	163.84
37533	AMAZ AMAZON.COM		508496	02/14/2020	26.95
37535	AMERIGIRL AMERICAN GIRL RETAIL INC.		508498	02/14/2020	128.00
37603	JEWELS JEWEL - OSCO		508562	02/14/2020	30.00
37642	PARCI PARTY CITY		508598	02/14/2020	34.96
37691	WALG WALGREENS CO.		508653	02/14/2020	19.98
					865.35
25-20-56-00600	EMPLOYEE RECOGNITION				
37615	MALNATIS THE MALNATI ORGANIZATION INC		508575	02/14/2020	93.14
					93.14
25-20-56-00646	SKATE SHOP SUPPLIES				
37532	AMAZ AMAZON.COM		508496	02/14/2020	7.49
37696	WRISTBAND WRISTBANDS.COM		508659	02/14/2020	240.00
					247.49
25-24-51-00111	WAGES - FULL TIME				

Park District of Oak Park

FY 2020

AP ACCOUNT DISTRIBUTION BY ACCOUNT OPEN & PAID VOUCHERS

CHECK DATES 02/01/2020 TO 02/29/2020 PAY DATES 02/01/2020 TO 02/29/2020

BOTH ACCRUALS AND NON ACCRUALS

CHECK RUN 0 TO 2147483647

<u>VOUCHER NUMBER</u>	<u>VENDOR</u>	<u>PO NUMBER</u>	<u>CHECK NUMBER</u>	<u>PAY DATE/ CHECK DATE</u>	<u>AMOUNT</u>
25-24-51-00111	WAGES - FULL TIME				
37270	ICMA ICMA RETIREMENT TRUST		26220	02/14/2020	983.70
					<u>983.70</u>
25-24-52-00222	MARKETING AND ADVERTISING				
37558	DOLL DOLLARTREE		508522	02/14/2020	8.28
37583	HOME HOME DEPOT		508547	02/14/2020	11.46
					<u>19.74</u>
25-24-52-11275	Gymnastics GI Joe				
37282	RODRIGUEZ UBALDO RODRIGUEZ		26232	02/14/2020	111.67
37346	PEDERSEN ALEK PEDERSEN		26286	02/21/2020	45.89
37350	RODRIGUEZ UBALDO RODRIGUEZ		26289	02/21/2020	29.04
37441	PEDERSEN ALEK PEDERSEN		26347	02/28/2020	23.00
					<u>209.60</u>
25-24-53-11250	PRESCHOOL GYMNASTICS CLASSES				
37673	STAPLES STAPLES BUSINESS ADVANTAGE DE		508633	02/14/2020	31.45
					<u>31.45</u>
25-24-53-11360	GYMNASTICS CENTER PROGRAMS				
37289	USAREGION USA GYMNASTICS REGION FIVE 20200151		26238	02/14/2020	202.00
37529	ALDI ALDI STORE		508491	02/14/2020	84.49
37554	CUZZOS CUZZOS PIZZA		508517	02/14/2020	116.53
37554	CUZZOS CUZZOS PIZZA		508517	02/14/2020	162.11
37558	DOLL DOLLARTREE		508522	02/14/2020	41.00
37581	HASTY HASTY AWARDS		508543	02/14/2020	876.66
37665	SIGNEXP SIGN EXPRESS		508627	02/14/2020	415.00
37673	STAPLES STAPLES BUSINESS ADVANTAGE DE		508633	02/14/2020	77.99
					<u>1,975.78</u>
25-24-56-00050	BOOSTER CLUB EXPENSE				
37004	CHMIEL TANYA CHMIELEWSKI		26170	02/07/2020	32.20
37006	DISCH DARIA DISCH		26172	02/07/2020	7.82
37007	EDWARDSDE DEMARCO EDWARDS		26173	02/07/2020	35.00
37267	ENERGYM ENERGYM GYMNASTICS	20200162	26217	02/14/2020	600.00
37283	SEKKI SARAH SEKKI		26233	02/14/2020	31.80
37346	PEDERSEN ALEK PEDERSEN		26286	02/21/2020	11.84
37418	EDWARDSDE DEMARCO EDWARDS		26329	02/28/2020	8.00
37422	FlipStar FLIPSTAR, INC.	20200257	26333	02/28/2020	600.00
37433	LIBERTY LIBERTYVILLE GYMNASTICS ACAD 20200256		26340	02/28/2020	340.00
37441	PEDERSEN ALEK PEDERSEN		26347	02/28/2020	18.52
37645	PERDIEM PERDIEM		508611	02/14/2020	18.95
37645	PERDIEM PERDIEM		508611	02/14/2020	39.26
37645	PERDIEM PERDIEM		508611	02/14/2020	12.26
37645	PERDIEM PERDIEM		508611	02/14/2020	16.35
37645	PERDIEM PERDIEM		508611	02/14/2020	23.08
37645	PERDIEM PERDIEM		508611	02/14/2020	5.00
37645	PERDIEM PERDIEM		508611	02/14/2020	50.00
37646	PERDIEM PERDIEM		508611	02/14/2020	20.61
37646	PERDIEM PERDIEM		508611	02/14/2020	11.31
37646	PERDIEM PERDIEM		508611	02/14/2020	6.93
37646	PERDIEM PERDIEM		508611	02/14/2020	24.66

Park District of Oak Park

FY 2020

AP ACCOUNT DISTRIBUTION BY ACCOUNT OPEN & PAID VOUCHERS

CHECK DATES 02/01/2020 TO 02/29/2020 PAY DATES 02/01/2020 TO 02/29/2020

BOTH ACCRUALS AND NON ACCRUALS

CHECK RUN 0 TO 2147483647

<u>VOUCHER NUMBER</u>	<u>VENDOR</u>	<u>PO NUMBER</u>	<u>CHECK NUMBER</u>	<u>PAY DATE/ CHECK DATE</u>	<u>AMOUNT</u>
25-24-56-00050	BOOSTER CLUB EXPENSE				
37646	PERDIEM PERDIEM		508611	02/14/2020	15.07
37647	PERDIEM PERDIEM		508611	02/14/2020	12.90
37647	PERDIEM PERDIEM		508611	02/14/2020	29.63
37647	PERDIEM PERDIEM		508611	02/14/2020	5.18
37647	PERDIEM PERDIEM		508611	02/14/2020	14.43
37647	PERDIEM PERDIEM		508611	02/14/2020	6.66
37647	PERDIEM PERDIEM		508611	02/14/2020	6.21
37647	PERDIEM PERDIEM		508611	02/14/2020	13.73
37647	PERDIEM PERDIEM		508611	02/14/2020	10.90
					<u>2,028.30</u>
25-24-56-00605	CONFERENCE AND TRAINING				
37779	PERDIEM PERDIEM		508611	02/14/2020	15.50
37779	PERDIEM PERDIEM		508611	02/14/2020	28.50
37779	PERDIEM PERDIEM		508611	02/14/2020	7.23
37779	PERDIEM PERDIEM		508611	02/14/2020	4.64
37779	PERDIEM PERDIEM		508611	02/14/2020	10.34
37779	PERDIEM PERDIEM		508611	02/14/2020	21.23
37779	PERDIEM PERDIEM		508611	02/14/2020	21.23
37779	PERDIEM PERDIEM		508611	02/14/2020	5.11
					<u>113.78</u>
25-24-56-00610	DUES AND SUBSCRIPTIONS				
37627	NATLCENT NATIONAL CENTER FOR SAFETY I		508586	02/14/2020	30.00
					<u>30.00</u>
25-24-56-00675	SALES TAX				
37271	ILLDEP ILLINOIS DEPT. OF REVENUE		26221	02/14/2020	62.00
					<u>62.00</u>
25-24-56-30150	GYM FUND RAISING IMPROVEMENTS				
37676	SYLV SYLVAN STUDIO		508637	02/14/2020	197.98
					<u>197.98</u>
25-50-52-00261	PROPERTY REPAIR - POOL				
36995	ALADEC ALARM DETECTION SYSTEMS, INC.	20200127	26161	02/07/2020	1,526.70 A
37044	VISTEEN VISTEEN PLUMBING INC.	20200157	26201	02/07/2020	3,750.00 A
					<u>5,276.70</u>
25-50-52-00262	PROPERTY REPAIR - RINK				
37015	HOH H-O-H CHEMICALS, INC.	20200041	26180	02/07/2020	275.00
37265	DUALTEMP DUAL TEMP ILLINOIS INC	20200045	26216	02/14/2020	942.80
37266	DUALTEMP DUAL TEMP ILLINOIS INC	20200154	26216	02/14/2020	942.80
37334	HOH H-O-H CHEMICALS, INC.	20200041	26271	02/21/2020	275.00
37416	DUALTEMP DUAL TEMP ILLINOIS INC	20200249	26327	02/28/2020	786.50
37432	KALISH KALISH ELECTRIC COMPANY	20200019	26338	02/28/2020	1,000.00
37561	EIC EIC, INC.		508524	02/14/2020	2,653.50
					<u>6,875.60</u>
25-50-52-00267	FLEET SERVICE - RINK				
37017	JORSON JORSON & CARLSON, INC.	20200030	26183	02/07/2020	413.06
					<u>413.06</u>
25-50-52-00301	CONTRACTUAL SERVICES- OTHER - RINK				
37255	AEREX AEREX PEST CONTROL INC.	20200035	26207	02/14/2020	103.00

Park District of Oak Park

FY 2020

AP ACCOUNT DISTRIBUTION BY ACCOUNT OPEN & PAID VOUCHERS

CHECK DATES 02/01/2020 TO 02/29/2020 PAY DATES 02/01/2020 TO 02/29/2020

BOTH ACCRUALS AND NON ACCRUALS

CHECK RUN 0 TO 2147483647

VOUCHER NUMBER	VENDOR	PO NUMBER	CHECK NUMBER	PAY DATE/ CHECK DATE	AMOUNT
25-50-52-00301	CONTRACTUAL SERVICES- OTHER - RINK				
37625	MOOD MOOD MEDIA NO AMERICA HOLDING:		508584	02/14/2020	26.95
					<u>129.95</u>
25-50-52-00302	CUSTODIAL SERVICE - GRC				
37263	CRYSTAL CRYSTAL MGMT & MAINTENANCE	20200148	26213	02/14/2020	2,495.00
37672	STANLEY STANLEY STEEMER		508632	02/14/2020	525.00
					<u>3,020.00</u>
25-50-52-00417	RINK EQUIPMENT-RENTAL				
37602	JACKS JACK'S RENTAL INC.		508560	02/14/2020	124.20
					<u>124.20</u>
25-50-53-00301	UNIFORMS				
37449	ULINE ULINE INC	20200247	26356	02/28/2020	41.00
					<u>41.00</u>
25-50-53-00312	SUPPLIES-CLEANING & HOUSEHOLD - POO				
37648	PETESFR PETE'S FRESH MARKET ROOSEVELT		508613	02/14/2020	6.35
					<u>6.35</u>
25-50-53-00314	SUPPLIES- BUILDING MATERIALS - POOL				
37629	NORTHERN NORTHERN TOOL & EQUIPMENT		508588	02/14/2020	674.99
					<u>674.99</u>
25-50-53-00315	SUPPLIES - CLEANING&HOUSEHOLD - RIN				
37399	CASELOTS CASE LOTS INCORPORATED	20200246	26311	02/28/2020	310.70
					<u>310.70</u>
25-50-53-00316	SUPPLIES - BUILDING MATERIALS - RIN				
37012	GRAINGER GRAINGER, INC.	20200128	26177	02/07/2020	85.82
37013	GRAND GRAND STAGE LIGHTING CO., INC.	20200129	26178	02/07/2020	565.12
37043	RAY KEVIN A. RAY	20191512	26187	02/07/2020	4,050.00 A
37430	GRAINGER GRAINGER, INC.	20200254	26336	02/28/2020	73.56
37444	RINK RINK SYSTEMS INC	20200252	26350	02/28/2020	308.77
37449	ULINE ULINE INC	20200247	26356	02/28/2020	281.86
37532	AMAZ AMAZON.COM		508496	02/14/2020	18.32
37532	AMAZ AMAZON.COM		508496	02/14/2020	11.90
37606	KEEN KEEN, INC.		508565	02/14/2020	35.00
37619	MENARDS MENARD'S		508578	02/14/2020	4.97
37683	UPS THE UPS STORE		508641	02/14/2020	242.50
					<u>5,677.82</u>
25-50-53-00319	MISC SUPPLIES - DOG PARKS				
37623	MODITY MODITY INC.		508582	02/14/2020	398.00
					<u>398.00</u>
25-50-53-00335	FUELS AND LUBRICANTS				
37419	FERRELL FERRELLGAS	20200042	26330	02/28/2020	62.57
					<u>62.57</u>
25-50-53-00340	POOL CHEMICALS				
36998	AQUA AQUA PURE ENTERPRISES, INC	20200146	26164	02/07/2020	5,969.47 A
36999	AQUA AQUA PURE ENTERPRISES, INC	20200146	26164	02/07/2020	2,497.75 A
					<u>8,467.22</u>
25-50-53-00415	BUILDING IMPROVEMENTS - POOL				
36995	ALADEC ALARM DETECTION SYSTEMS, INC.	20200127	26161	02/07/2020	1,500.00 A

Park District of Oak Park

FY 2020

AP ACCOUNT DISTRIBUTION BY ACCOUNT OPEN & PAID VOUCHERS

CHECK DATES 02/01/2020 TO 02/29/2020 PAY DATES 02/01/2020 TO 02/29/2020

BOTH ACCRUALS AND NON ACCRUALS

CHECK RUN 0 TO 2147483647

VOUCHER NUMBER	VENDOR	PO NUMBER	CHECK NUMBER	PAY DATE/ CHECK DATE	AMOUNT
50-00-55-00552	LIFE INSURANCE				
37362	PDRMA PDRMA		26285	02/21/2020	558.21
					<u>558.21</u>
50-00-55-00553	DENTAL INSURANCE				
37362	PDRMA PDRMA		26285	02/21/2020	3,221.13
					<u>3,221.13</u>
50-00-55-00554	EMPLOYEE ASSISTANCE PROGRAM				
37362	PDRMA PDRMA		26285	02/21/2020	184.80
					<u>184.80</u>
50-00-55-00557	VISION INSURANCE				
37362	PDRMA PDRMA		26285	02/21/2020	1,060.42
					<u>1,060.42</u>
					<u>71,115.64</u>
					FUND 50 TOTAL

70 CAPITAL PROJECTS

70-00-72-00960	PROPERTY ACQUISITION				
37363	COOKCTY COOK COUNTY TREASURER	20200226	26251	02/21/2020	8,631.62
37364	COOKCTY COOK COUNTY TREASURER	20200226	26252	02/21/2020	8,632.04
37365	COOKCTY COOK COUNTY TREASURER	20200215	26255	02/21/2020	4,360.32
37366	COOKCTY COOK COUNTY TREASURER	20200225	26256	02/21/2020	4,063.23
37367	COOKCTY COOK COUNTY TREASURER	20200225	26257	02/21/2020	5,570.26
37368	COOKCTY COOK COUNTY TREASURER	20200225	26258	02/21/2020	6,490.78
37369	COOKCTY COOK COUNTY TREASURER	20200225	26259	02/21/2020	846.55
37370	COOKCTY COOK COUNTY TREASURER	20200225	26260	02/21/2020	7,002.97
37371	COOKCTY COOK COUNTY TREASURER	20200225	26261	02/21/2020	7,713.40
37372	COOKCTY COOK COUNTY TREASURER	20200225	26262	02/21/2020	3,204.75
37373	COOKCTY COOK COUNTY TREASURER	20200225	26253	02/21/2020	2,353.16
37374	COOKCTY COOK COUNTY TREASURER	20200225	26254	02/21/2020	2,513.02
					<u>61,382.10</u>
70-00-72-70330	PROPERTY REPAIRS AND REHAB				
37349	PREMIERM PREMIER MECHANICAL INC	20200182	26288	02/21/2020	4,942.06
					<u>4,942.06</u>
70-12-72-70200	BARRIE BUILDING IMPROVEMENTS				
37022	WINDFREE WINDFREE WIND & SOLAR ENER	20200126	26205	02/07/2020	23,076.00
					<u>23,076.00</u>
70-13-72-70150	CARROLL MASTER PLAN IMPROVEMENTS				
37005	DILLEY TOM BASSETT-DILLEY ARCHITECT L	20200111	26171	02/07/2020	4,995.00
37276	ORBIS ORBIS CONSTRUCTION COMPANY INC	20200149	26227	02/14/2020	94,570.20
37306	ADVANCED ADVANCED GEOTHERMAL PLUM	20200193	26241	02/21/2020	46,500.00
37320	DILLEY TOM BASSETT-DILLEY ARCHITECT L	20200175	26263	02/21/2020	3,884.85
37438	OLEARYS O'LEARY'S CONTRACTORS EQUIPM	20200242	26344	02/28/2020	2,061.00
37610	LANCE LANCE CONSTRUCTION		508569	02/14/2020	582.12
37663	SHERWIN SHERWIN-WILLIAMS CO.		508626	02/14/2020	75.52
					<u>152,668.69</u>
70-17-72-70250	STEVENSON PARK IMPROVEMENTS				
37021	NUTOYS NUTOYS LEISURE PRODUCTS	20200125	26188	02/07/2020	17,982.00 A
37333	HACIENDA HACIENDA LANDSCAPING INC.	20200192	26270	02/21/2020	118,273.50
					<u>136,255.50</u>

Park District of Oak Park

FY 2020

AP ACCOUNT DISTRIBUTION BY ACCOUNT OPEN & PAID VOUCHERS

CHECK DATES 02/01/2020 TO 02/29/2020 PAY DATES 02/01/2020 TO 02/29/2020

BOTH ACCRUALS AND NON ACCRUALS

CHECK RUN 0 TO 2147483647

VOUCHER NUMBER	VENDOR	PO NUMBER	CHECK NUMBER	PAY DATE/ CHECK DATE	AMOUNT
70-20-72-70150	REHM MASTER PLAN IMPROVEMENTS				
37356	V3 V3 COMPANIES	20200183	26296	02/21/2020	3,900.00
					<u>3,900.00</u>
70-35-72-70150	CONSERVATORY MASTER PLAN IMPROVEMEN				
37020	MCDONTIM TIM MCDONALD	20200124	26198	02/07/2020	6,125.00
					<u>6,125.00</u>
70-74-72-70100	RANDOLPH TOT LOT SITE PLAN				
37308	ALTA ALTAMANU, INC.	20200187	26243	02/21/2020	2,483.97
37309	ALTA ALTAMANU, INC.	20200187	26243	02/21/2020	1,990.22
37310	ALTA ALTAMANU, INC.	20200187	26243	02/21/2020	4,304.87
37356	V3 V3 COMPANIES	20200183	26296	02/21/2020	1,750.00
					<u>10,529.06</u>
70-75-72-70150	WENONAH MASTER PLAN IMPROVEMENTS				
37308	ALTA ALTAMANU, INC.	20200187	26243	02/21/2020	2,483.98
37309	ALTA ALTAMANU, INC.	20200187	26243	02/21/2020	1,990.23
37310	ALTA ALTAMANU, INC.	20200187	26243	02/21/2020	4,304.88
37356	V3 V3 COMPANIES	20200183	26296	02/21/2020	1,750.00
					<u>10,529.09</u>
					<u>409,407.50</u>
					FUND 70 TOTAL
					409,407.50
85 CHENEY MANSION					
85-00-52-00260	PROPERTY REPAIR				
37354	UNITEDANA UNITED ANALYTICAL SERVICES	20200191	26294	02/21/2020	565.00
37420	FIRESIE FIRE SCIENCE TECHNIQUES	20200237	26331	02/28/2020	336.00
					<u>901.00</u>
85-00-52-00275	CUSTODIAL SERVICES				
37037	UNIFIRST UNIFIRST CORPORATION	20190138	26200	02/07/2020	82.60 A
37254	AEREX AEREX PEST CONTROL INC.	20200167	26207	02/14/2020	61.00
37288	UNIFIRST UNIFIRST CORPORATION	20200166	26237	02/14/2020	82.60
37315	BRENNANS CHRISTOPHER BRENNANS	20200177	26245	02/21/2020	125.00
37391	AEREX AEREX PEST CONTROL INC.	20200167	26304	02/28/2020	61.00
					<u>412.20</u>
85-00-52-00299	CONTRACTUAL SERVICES - OTHER				
37671	SPOTIFY SPOTIFY		508631	02/14/2020	9.99
					<u>9.99</u>
85-00-52-11185	CHENEY ADULT PROGRAMS				
37001	CARNIVORE CARNIVORE INC.	20200150	26167	02/07/2020	360.00 A
37019	MAYADEL MAYA DEL SOL LLC	20200155	26186	02/07/2020	871.88
37286	THORNTON MICHAEL B. THORNTON	20200165	26235	02/14/2020	250.00
37290	ZEEMAN TERRY ZEEMAN	20200164	26239	02/14/2020	200.00
37311	ANGIES ANGIE'S PANTRY INC.	20200206	26244	02/21/2020	814.00
37344	PARKINSON ANDREA MILLER PARKINSON	20200207	26283	02/21/2020	580.15
					<u>3,076.03</u>
85-00-53-00311	SUPPLIES- CLEANING & HOUSEHOLD				
37453	WAREHOUS WAREHOUSE DIRECT OFFICE	20200205	26361	02/28/2020	1,422.00
37453	WAREHOUS WAREHOUSE DIRECT OFFICE	20200205	26361	02/28/2020	-1,137.60
37454	WAREHOUS WAREHOUSE DIRECT OFFICE	20200205	26361	02/28/2020	159.00
37649	PETESFR PETE'S FRESH MARKET ROOSEVELT		508613	02/14/2020	37.67

Park District of Oak Park

FY 2020

AP ACCOUNT DISTRIBUTION BY ACCOUNT OPEN & PAID VOUCHERS

CHECK DATES 02/01/2020 TO 02/29/2020 PAY DATES 02/01/2020 TO 02/29/2020

BOTH ACCRUALS AND NON ACCRUALS

CHECK RUN 0 TO 2147483647

<u>VOUCHER NUMBER</u>	<u>VENDOR</u>	<u>PO NUMBER</u>	<u>CHECK NUMBER</u>	<u>PAY DATE/ CHECK DATE</u>	<u>AMOUNT</u>
					481.07
85-00-53-00313	SUPPLIES - BUILDING MATERIALS				
37583	HOME HOME DEPOT		508547	02/14/2020	175.92
					175.92
85-00-56-00605	CONFERENCE AND TRAINING				
37528	AIRPORT AIRPORT LIMOUSINE SERVICE			02/14/2020	-100.00
					-100.00
85-00-58-00800	ELECTRICITY				
37318	COMED COMED	20200200	26249	02/21/2020	33.83
37401	COMED COMED	20200223	26313	02/28/2020	307.26
					341.09
85-00-58-00830	WATER				
37734	VILLWAT VILLAGE OF OAK PARK-WATER WA1		508652	02/14/2020	95.75
					95.75
					5,393.05
				FUND 85 TOTAL	
99 MEMORIAL TRUST					
99-20-53-00320	MISCELLANEOUS SUPPLIES				
37316	BRON BRONZE MEMORIAL COMPANY	20200180	26247	02/21/2020	114.81
					114.81
				FUND 99 TOTAL	114.81
				GRAND TOTAL	1,040,227.69

Corporate Fund	\$ 279,259.93
IMRF Fund	\$ -
Liability Fund	\$ 126,260.82
Audit Fund	\$ -
Recreation Fund	\$ 61,256.02
Museum Fund	\$ 488.11
Special Recreation Fund	\$ -
Revenue Facilities	\$ 86,931.81
Insurance Fund	\$ 71,115.64
Capital Projects	\$ 409,407.50
Cheney Mansion Fund	\$ 5,393.05
Memorial Trust	\$ 114.81
Grand Total	\$ 1,040,227.69

To the Executive Director,

The Payment of the above listed accounts has been approved by the Board of
Commissioners at their meeting held March 19, 2020

And you are hereby authorized to pay them from the appropriate funds.

(Treasurer)

(Secretary)

Commissioner

**Park District of Oak Park
Committee of the Whole
Hedges Administrative Center
Oak Park, Illinois
Thursday, February 13, 2020**

Minutes

The meeting was called to order at 7:32pm.

I. Roll Call

Present: Commissioners Worley-Hood, Wollmuth and President Lentz. Commissioners Porreca and Wick were absent.

Park District Staff present: Jan Arnold, Executive Director; Chris Lindgren, Superintendent of Parks and Planning; Diane Stanke, Director of Marketing and Customer Service; Kyle Cratty, Director of Finance; and Karen Gruszka, Executive Assistant.

Others Present: Residents.

II. Public Comment

Haviva Siegal – wanted to update the Board on what she was hearing around the community. She said that she has heard good things about the constant contact that went out after the holidays. She said that she has found out that the renovations at Wenonah and Randolph Parks will be taking place at the same time and wanted to know if a reminder will be going out on other options for residents with little ones looking for fenced in parks. Also she wanted to know if updated drawings will be on the web and if there will be community meetings for participation.

III. Administration and Finance Committee

A. Park District Citizen Committee Update

Laura Stamp, PDCC Chair, informed the Board of what the committee has been doing throughout the year including being a part of the strategic plan and making sure items are placed on the web for increased transparency. While being a part of the plans, they want to make sure that the designs are inclusive and meet any concerns residents may have; they all feel inclusiveness is an important area to develop and they must look through that lens. They also want more natural areas in all the parks and climbing rocks for the kids. They continue to look to increase diverse membership age-wise and ability-wise on the committee. They are revamping the secret shopper program as the past way it was run, members were not able to keep up with the commitments but all felt it was a program to continue, so they are coming up with different ways to keep it running. They were part of the beta group for the new Amilia registration software and were very excited when it came out. The Board thanked them for their work and volunteering within the District.
No action is needed by the Board on this item.

B. The VOP Parking Agreement Update

Due to the transfer of the Highland Madison lots to the Park District, a new intergovernmental parking agreement needed to be crafted. The new agreement will address the VOP's continued selling of 32 vehicle parking passes for lot 44, no charges will be assessed on the VOP for this use. The VOP will be responsible to maintain lot 44 including signage and snow removal for their permit holders, the PDOP will provide 90 days notice to VOP for stoppage of use, and the

VOP to provide street parking on Adams for employees once the CRC construction begins. **This will come before the Board on the regular agenda at the February Regular Board Meeting.**

C. Information and Technology Contract

The Board was reminded of the open IT Manager position. Looking at the PDOP's options, staff recommends moving forward with outsourcing IT services and support. Joe Wright, owner of Noventech, has written the code for importing data into Mpower for the past seven years, has a variety of skills with eight employees, will be on staff 16 hours per month, the cost is equal to the salary of an IT Manager, and the contract will be evaluated after six months. The Board confirmed the relationship with Noventech and their responsiveness, references, and the six month satisfaction check and the ability to end the relationship at that time if the Park District is not satisfied. **This will come before the Board on the consent agenda at the February Regular Board Meeting.**

III. Recreation and Facility Program Committee

A. Festival Theater Agreement

Jan Arnold, Executive Director, informed the Board that the Festival Theater Agreement has been both a three-year agreement and a one-year agreement; and with the new Executive Director of Festival Theater, this will be a one-year agreement. This year Festival Theater will be planning to hold one production due to the weather impacts in previous years. They are again asking for a \$6,000 contribution from the Austin Trust. As Festival Theater did last year, they will be paying the Park District \$1 per ticket sold to help offset maintenance of the park during their season and again will be holding free Community Nights. These tickets will be distributed by the PDOP Customer Service so that tickets are distributed only to residents in the amount of the household. The Board discussed the dispersion of the tickets with Amilia and their new Executive Director. **This will come before the Board at the April Regular Board Meeting under the consent agenda at the February Regular Board Meeting.**

IV. Parks and Planning Committee

A. Rehm Professional Services*

Executive Arnold informed the Board that Altamanu, Inc. updated the Rehm Master Plan in 2016. The 2020-2024 CIP has \$800,000 allocated for improvement at Rehm Park in 2020 and the District received a \$400,000 OSLAD grant bringing the total to \$1,200,000. The improvements will include a new playground, entrance, picnic pavilion, restroom as well as bags and table tennis games. Altamanu, Inc. will provide the Landscape Architectural Services for \$69,650 and SMP Group Design Associates, LLC will provide Civil Engineering scope items as related for \$26,000 for a total of \$95,450 in professional fees as well as approximately \$1,200 in additional expenses. The Board asked if the old playground equipment would be donated which was confirmed that Playgrounds Around the World would come and inspect equipment to see viability of donations. **This will come before the Board on the regular agenda at the February Regular Board Meeting.**

VI. New Business - None

VII. Executive Session

At 8:07pm Commissioner Worley-Hood moved and Commissioner Wollmuth seconded that the Park Board of Commissioners convene into closed session for the discussion of the appointment, compensation, discipline, performance or dismissal of specific employee(s) or legal counsel of the District. **The motion passed with a roll call vote of 3:0.**

At 8:56pm a motion was made by Commissioner Worley-Hood and seconded by Commissioner Lentz to adjourn the Closed Session. **The motion passed a voice vote of 3:0.**

VIII. Adjournment

At 8:56p.m. a voice vote was taken to adjourn the Committee of the Whole Meeting. **Motion carried in a voice vote.**

Secretary
Board of Park Commissioners

March 19, 2020
Date

President
Board of Park Commissioners

March 19, 2020
Date



PARK DISTRICT
of OAK PARK

**Park District of Oak Park
Regular Board Meeting
Hedges Administrative Center
218 Madison Street, Oak Park, Illinois
Thursday, February 20, 2020**

Minutes

The meeting was called to order at 7:30pm.

I. ROLL CALL

Present: Commissioners Wick, Wollmuth, Worley-Hood, and President Lentz. Commissioner Porreca was absent.

Park District Staff Present: Jan Arnold, Executive Director; Chris Lindgren, Superintendent of Parks and Planning; Kyle Cratty, Director of Finance; Maureen McCarthy, Superintendent of Recreation; Bill Hamilton, Superintendent of Special Facilities; Paula Bickel, Director of Human Resources; Diane Stanke, Director of Marketing and Customer Service; Jamie Lapke, Program and Operations Manager – GRC; Chad Druke, Program Manager; Mike Loszach, Program Manager; Kayla Fauria, Aquatic & Rink Program Manager; Patti Staley, Director of Horticulture & Conservatory Operations; and Karen Gruszka, Executive Assistant.

Others Present: Don Nekrosius; Nancy Teclaw, OPRF Senior Citizens' Center's Board; and residents.

II. APPROVAL OF AGENDA

No changes to the Agenda. **The motion was passed by a voice vote.**

III. COMMUNITY SERVICE AWARDS

The Park Board presented the Community Service Awards to the following recipients: Don Nekrosius and the OPRF Senior Citizens' Center's Board. Don thanked the Board and District and stated that the Park District has made a difference in his life and he has loved volunteering. Nancy stated she really appreciates the award and that the combined Senior Citizens' Center was a long time coming and that it was great to work with the Park District and watch the memberships increase and the use of the new space. The Board thanked them for their many hours of service and selfless devotion to their community. A brief reception took place for the awardees.

IV. VISITOR/PUBLIC COMMENTS

Dane Rankin – Stated he was the Vice President of OPYB/S and was tasked with the scheduling of the teams. He was coming to the PDOP to ask that the duplication of programs competing with theirs stop as it is confusing for those that are signing up expecting one and getting the other and that the duplicate programs is taking up space on the already crowded fields. He feels we can do better with more open communication, planning, and placement of correct ages/sports on the correct fields. Their organization is 90% Oak Park River Forest residents and feels priority should be given to tax paying residents first and that residents should not have to travel outside of Oak Park for their sports due to non-residents using the fields.

Brian Endless – Informed the Board he will be phasing out as President of OPYB/S and Sam Ellison will be the new incoming president. He went on to say that he would like to build a relationship with the boards of both organizations and staff and rectify the overlap of duplication of effort. They have heard from families where they saw baseball in our brochure and signed up thinking it was the OPYB/S league thinking they were signing up for the league that their child's friends were on. Better placement of age groups on appropriate fields needs to happen. They would like better communication between the written request for space on paper they send in at the beginning of the season and what is said to be "a draft of space" they get back but is really more of a final

document as changes can rarely be made to it. He was here to ask for the ability to discuss the requests before they are made into the “draft” schedule they receive back.

Haviva Siegel – Came back to compliment the Park District on all the communication that is going out and wanted to let them know that residents are really noticing the information and appreciating it. She also wanted to ask the Board when the new drawings for the Rehm project would be coming out. This is the OSLAD grant project and she wanted to see the updated drawings with the new monies awarded. She also asked who was going to be looking into the details of the playground, what the process is to make sure of inclusiveness. She stated an example of a zip-line piece of equipment; that for it to be inclusive, there must be two zip-lines next to each other, one being ADA accessible, with the other allowing someone to go down alongside the ADA accessible zip-line.

Nakhab Nadeen – Stated he has lived in Oak Park for 16 years and is part of the AYSO organization. He thanked the Park District for all their support over the years. Their board was looking for the possibility to explore a U8/U6 soccer partnership. They are hoping to introduce the sport at that age and give children the opportunity to learn and play at an earlier age than what has been in the past.

V. CONSENT AGENDA

A motion was made by Commissioner Worley-Hood and seconded by Commissioner Wick to approve the Consent Agenda, which includes the Cash and Investment Summary and Warrants and Bills for the month of January, 2020; approve minutes from the Committee of the Whole Meeting January 9, 2020, the Regular Board Meeting January 16, 2020; approve the Festival Theater Agreement; and approve the Engagement Letter – Elrod Friedman LLC. **The motion passed with a roll call vote of 4:0.**

VI. STAFF REPORTS

A. Director’s Report

Jan Arnold, Executive Director, informed the Board that due to Mother Nature not cooperating this winter, the outdoor ice rinks will begin to be dismantled. The outdoor liners were never put into the rinks due to the lack of continuous freezing weather but they will be able to be used next year. The Ice Show is March 13-15, it’s a wonderful exhibit of the skaters of all ages in our programs. The brochures will be arriving at residences this weekend and she informed the Board that the childcare discount had increased by 98 children from this time in 2019.

B. Division Managers’ Reports (Updates & Information) – Written Report Included in Board Packet.

C. Revenue/Expense Status Report – No questions asked.

VII. OLD BUSINESS

A. Recreation and Facility Program Committee - None

B. Parks and Planning Committee

1. Rehm Professional Services.

Commissioner Wick moved and Commissioner Wollmuth seconded for the Board to approve the authorization to engage Altamanu, Inc., Chicago, Illinois, for a total cost not to exceed \$96,650, to create project bid specifications and to provide oversight of construction for the Rehm Park Improvements. Altamanu, Incorporation’s fee is \$69,650, and will serve as the lead consultant and SMP Group Design Associates, LLC, will be the sub-contractor with a fee of \$26,000. Executive Director Arnold reminded the Board that Altamanu, Inc. updated the master plan for Rehm in 2016. The budget of \$1,200,000 was comprised of \$800,000 in the budget with a \$400,000 OSLAD grant. The improvements to the park include: a new playground, entrance, picnic pavilion, restroom, and bags and table tennis games. The Board questioned the process with IDNR and was informed that they ensure plans are ADA accessible and have a variety of equipment/plans for all ages. SMP Group Design Associates, LLC, will work with the design elements and in compliance with ADA. The Board discussed the timeline,

and were informed the trains would be closed from July through December but would be back and that Fallfest would be moved to Maple Park. **The motion passed with a roll call vote of 4:0.**

C. Administration and Finance Committee

1. Information Technology Services

Commissioner Worley-Hood moved and Commissioner Wick seconded that the Park Board of Commissioners approve engaging Noventech, Inc., of Wood Dale, IL, for information technology services and support for \$8,850 per month. Staff request approval for a one-year contract with the ability to extend based on service delivery. The Board was reminded that staff have been reviewing options for the needs of the District with the resignation of the IT Manager, Michael Elden, for several months. Noventech was chosen due to their staff of nine with multiple skills, having a designated tech on site a minimum of 16 hours per month, and the cost savings. This company has other Park Districts as customers, the owner has written the code for our Mpower data for the past seven years, and staff our confident with his responsiveness. This will be on a trial basis for six months and will only be extended if the PDOP is completely satisfied. **The motion passed with a roll call vote of 4:0.**

2. Intergovernmental Agreement - Parking

Commissioner Worley-Hood moved and Commissioner Wick seconded that the Park Board of Commissioners approve the VOP and PDOP Intergovernmental Agreement for parking effective April 1, 2020. The Board was reminded that with the transfer of the property for the CRC, the VOP's parking lots were now owned by the Park District. This new IGA for the parking allows the Village to continue to sell permits for Lot 44 until construction begins. Staff will be given parking on Adams at the time of construction for the CRC. The Board were pleased that the Village was able to continue offering parking spaces to the residents with this IGA. **The motion passed with a roll call vote of 4:0.**

VIII. NEW BUSINESS

1. Annual Recreation Department Report

Maureen McCarthy, Superintendent of Recreation; Mike Loszach, Program Manager-After School, Early Childhood, Day Camp, and Teens; and Chad Drufke, Program Manager – Sports and Fitness; reviewed the 2019 Comprehensive Program Participation Report and answered questions pertaining to the data presented including: wellness, martial arts, youth and adult sports, teens, fine arts, early childhood, nature & environmental, community events, and general programming. The Board discussed the holiday special events and their support to Sarah's Inn and Beyond Hunger, how well moving the Day in the Village event to Mills Park worked, and they wondered if we could partner with some businesses between Mills Park and Scoville Park that day for more enticement to Mills Park. The Board was also informed that a planned event at Scoville Park for Unplug Illinois will take place this summer. The Board asked for clarification on possible duplications with OPYB/S and were informed that the Park District runs an instructional 3-5 year old program which leads into OPYB/S's T-ball league, and prior to them having a coach's pitch league, the Park District ran an instructional league that helped the kids adjust from the T-ball to the ball being pitched over the plate. Most of the programs run by the District run in July on a once a week basis to let kids explore their desire to play baseball before going into the much more scheduled OPYB/S league. The Board thanked staff for their reports. **No action is needed by the Board on this item.**

2. Annual Special Facilities Report

Bill Hamilton, Superintendent of Special Facilities, Kayla Fauria, Program Manager – Aquatic and Rink, and Jamie Lapke, Program and Operations Manager – GRC, presented the 2019 Annual Special Facilities Report. Items discussed were the pools' past season, weather and its effects on attendance for the pools, life guards, passes, and the swim lessons. The ice arena operations were presented including: hockey and their numbers and the changes in the program format from just doing skills to more playing and having fun, camps, lessons, and open skates. The Board was informed of changes made to the adult hockey league's standards to make it safer for everyone. Jamie said that the gymnastic center had been open six years as of October. She discussed their programs and different levels, meets, open gym, and special programs, including: increased family activities, Ninja programs, and their first Adult Gymnastic Competition which was a huge success! The Board was informed with the drop of the fee for resident's dog park passes, the passes jumped from 300 to

642. Discussion took place on the decline of participation in hockey and what plans the Park District had to increase interest; they discussed the revamping of the leagues for more play, marketing of the leagues in surrounding towns, and discounts for programs when passes were purchased. **No action is needed by the Board on this item.**

3. Annual Report

The Board was informed briefly of the information on the Annual Report and that it would be an insert in the spring brochure going out next weekend. **No action is needed by the Board on this item.**

4. Wenonah and Randolph Park Construction Contract Approval

The Park District has gone out to bid for these projects on February 6. Twenty-six registrations to download the packet has taken place. A pre-bid meeting was held which no one attended but staff are confident we will receive a good amount of bids. The Board confirmed that both projects were being bid together and were reminded that it was for rolling hills and outdoor exercise equipment at Randolph and a new rubberized surface, the removal of the sand, a new swings at Wenonah. **This will be brought to the Board under the regular agenda at the Continued Board Meeting on March 5.**

IX. COMMISSIONERS' COMMENTS

- **Commissioner Wick** – Thanked the people that came in for public comment, saying the Board appreciates their comments. He attended FOPCON's meeting the past Monday and they are working hard on getting the EL stop name changed to the Oak Park Conservatory stop which is no cost to the Park District but would improve visibility. He also attended the IGOV tax forum and stated it was a great event with Senator Don Harmon in attendance along with Ali ElSaffar, Township Assessor, and Fritz Kaegi, Cook County Assessor there. He also wanted to confirm communication is brought to Park District patrons regarding the Lake Street construction.
- **Commissioner Porreca** – Absent.
- **Commissioner Wollmuth** – Thanked the residents in attendance for their public comments made and said he hopes it is the starting point for more communication and it is great for getting different perspectives.
- **Commissioner Worley-Hood** – Attended the Pleasant Home meeting last week and said they are working on their strategic plan and their renewal of their contract with the Park District. He also attended the Active Adults Committee meeting and said they have grown so much they are bursting at the seams. It is great to attend their meetings and see all the spaces being used by programs in progress.
- **Commissioner Lentz** – Said she had attended the IGOV meeting as well and said it was just great to see the residents being able to get questions answered in one on one discussions at the end of the meeting.

X. EXECUTIVE SESSION

At 9:32pm Commissioner Worley-Hood moved and Commissioner Wick seconded that the Park Board of Commissioners convene into closed session for the discussion of performance of a specific employee of the Park District. **The motion passed with a roll call vote of 5:0.**

At 9:58pm a motion was made by Commissioner Wick and seconded by Commissioner Worley-Hood to adjourn the Closed Session. **The motion passed a voice vote of 5:0.**

XI. Meeting Adjourned

At 10:18 the Regular Board meeting was continued to March 5, 2020. **The motion passed with a voice vote.**

Secretary
Board of Park Commissioners

March 19, 2020

Date

President
Board of Park Commissioners

March 19, 2020

Date



Memo

To: Kassie Porreca, Chair, Administration and Finance Committee
Board of Park Commissioners

From: Jan Arnold, Executive Director

Date: March 11, 2020

Re: Park District Citizen Committee Application



Statement

The Park District Citizen Committee was established in fall 2003, to oversee the development of the Comprehensive Master Plan. Since the plan's completion, the charge of the PDCC has been to oversee the implementation of the Comprehensive Master Plan and the development and ongoing review of park site plans, as well as to provide a valuable communication channel between the Park District and the citizens of Oak Park. The Mission and Guiding Principles of the Park District Citizen Committee state the committee should include 11 members, two alternates, and two student representatives.

Discussion

There are currently 10 members on the committee. Lauren Johnson has expressed interest in joining the Park District Citizen Committee. Lauren has attended several PDCC meetings and has a background in occupational therapy. Lauren wants to be more involved in the community and share her expertise.

Conclusion

The Administration and Finance Committee recommend that the Park Board approve the appointment of Lauren Johnson as a member of the Park District Citizen Committee to serve a three-year term.

Attachment: Application



PARK DISTRICT
of OAK PARK

PARK DISTRICT OF OAK PARK

218 Madison Street • Oak Park, IL 60302 • (708) 725-2000 (info) • (708) 725-2301 (fax) • www.pdop.org

In partnership with the community, we enrich lives by providing meaningful experiences through programs, parks and facilities.

Committee Interest Application

Thank you for your willingness to serve your community on one of our volunteer citizen's committees. The following information will assist the Park District in determining the best position for you to utilize your experience, abilities and interests.

INSTRUCTIONS: Please complete and submit this application for review to the location listed above.

Committee you are interested in joining: (please check all that apply)

- Park District Citizen Committee (PDCC)
- Environmental Sustainability Advisory Committee (ESAC)
- Active Adult Advisory Committee (AAAC)

APPLICANT INFORMATION Please note, Oak Park residency is required to apply.

Applicant Name Lauren K. Johnson

Address 1164 Clinton Ave.

City OP State IL Zip 60304

Email Address laurenptdptpcs@gmail.com

Daytime Phone 314-704-4315 Evening Phone ← same

Age of Applicant: Up to 29 years 30-54 years 55 years & up

What park and public space are closest to your residence? Carroll Park

AVAILABILITY

Please indicate your availability on a regular basis: **CHOOSE ONE:** Daytime Evening Anytime (as needed)

CHOOSE ONE: Weekly Semi-monthly Monthly Intermittently

EDUCATIONAL DATA

Degrees (if any) BS in Exercise Science, Master's Doctorates in Physical Therapy

Other Educational Experience former director of adaptive biking nonprofit, member & leader of Louisiana obesity council

COMMUNITY ACTIVITIES, PROFESSIONAL ORGANIZATIONS OR OTHER INTERESTS

Please list any activities you are currently involved with: professional organizations, PDOP activities (kid sports, camps, preschool), running

Please indicate how you can best be of service to the Park District of Oak Park: perspectives I can offer are as a heavy PDOP user, parent of young children, and healthcare provider

Applicant's Signature: Lauren K. Johnson Date 2/24/20

You are welcome to attach additional information in a resume or write on the back of this form.

Executive Director's Report

From the desk of Jan Arnold

Friday, February 13, 2020

1. **Upcoming Board Meetings** – The March Regular Board Meeting is scheduled for Thursday, March 19, 2020, at the Hedges Administrative Center. The April Committee of the Whole Meeting is scheduled for Thursday, April 2, 2020, at the Hedges Administrative Center. The March Regular Board Meeting is scheduled for Thursday, April 16, 2020, at the Hedges Administrative Center. All meetings will begin at 7:30pm. At the end of my report are some events you may consider stopping by.
2. **IAPD Legislative Conference** – The Annual IAPD Legislative Conference will be held on Wednesday, April 29, 2020, at the Crowne Plaza Hotel in Springfield. Attending along with myself will be Commissioners Lentz and Wick as well as Bill, Chris, Maureen, and Diane. Maureen and Diane will go down a day early and participate in the Park Day at the capital with a table full of PDOP information.
3. **Community Service Awards** – It was our pleasure at the February Regular Board Meeting (February 20), to recognize an individual and an agency for their outstanding service and dedication toward the advancement of parks, recreation and leisure in the Oak Park community and Illinois. The following were recognized as recipients of the PDOP's Community Service Awards: Don Nekrosius and the OPRF Senior Citizens' Center's Board.
4. **Outdoor Ice Rinks** – The outdoor ice rinks are deconstructed for the year. All liners purchased will be able to be used next year.
5. **Carroll Center** – Tom Basset-Dilley Architects (Architect/CM). The Park District will assume the role of General Contractor on this project. The triple glazed windows and entry doors were installed the week of February 14. Exterior insulation is installed on the building. Exterior siding work has started on the East wall and will continue over the next two weeks. The rough framing inspection was passed on February 12, and interior spray foam insulation was completed on February 27. HVAC rough in ductwork and equipment installation is underway and should be completed late March. The Passive House reviewer was on site March 5, to complete a mid-construction blower door test to get baseline information on the air barrier performance. This test came back extremely positive with the facility already meeting the final air infiltration levels needed for certification. The solar contractor installed support rods on the south wall of the building and will be back on site to install solar in mid-April. Drywall hanging and taping will start on March 16, and looks to be completed in early April. The partition wall in the new space is on order and the track will be installed next week.
6. **Rehm Tennis Courts** – SMP Group Design Associates (Engineer). Evans and Sons Paving (General Contractor). The project started on September 4, with site fencing and windscreen. The asphalt surfacing was finished on September 25, and needed a minimum of two weeks to cure before applying the acrylic color coating. The weather has been problematic with temperatures dropping below 50 degrees, so we are currently in a holding pattern on the acrylic coloring surface. The fencing work has been completed and the landscaping restoration is complete as well. The Gaga Pit is installed in its new location on the southwest portion of the park. The site will remain fenced off until spring if the temperatures stay below 50 degrees. The coating contractor has confirmed that we are the first project that will get done this year.
7. **OSLAD Grants** – The PDOP submitted two projects for consideration. On Thursday, October 12, an IDNR representative toured Rehm for the OSLAD grant. Chris and I went to Springfield on Tuesday,

November 5, to present our projects for funding. Both projects were funded; \$400,000 for Rehm Park and \$192,000 for property adjacent to Carroll Park.

8. **Stevenson Park Improvements** – Altamanu (Landscape Architect). Hacienda Landscaping (General Contractor). The Park District received notification of a \$400,000 OSLAD grant for this project. The project started on July 29. The old playground was donated to Kids Around the World where it will be repurposed in another country of need. The project and the punchlist has been completed and the new turf mounds were installed on March 10. The grand re-opening of the park is scheduled on Saturday, April 18.
9. **Randolph & Wenonah**- Altamanu (Landscape Architect). Staff held a project kick-off meeting on November 25, to have an overview of the project. The parks will be bid as one overall project to help save costs of splitting the project. This project went out to bid on February 24, and a contract was awarded at the March 5, Continued Regular Board Meeting. A pre-construction site meeting took place on March 11 to review the plan details. Anticipated construction will begin in April of 2020.
10. **Scoville Playground** – The playground's poured in place surface failed and an emergency contract was awarded to install synthetic grass similar to the new surface at Stevenson Park. The contractors began to tear out the material on Monday, February 10. The surfacing is completed and new sand was added to the sand box. The playground was opened to the public on March 2.

March

- **March 13-15 – Ice Show – RCRC * RESCHEDULED May 29-31, 2020**
- **March 19 – Regular Park Board Meeting – 218 Madison Street from 7:30pm – 9:00pm**
- **March 31 – Active Adults Chicago Mob and Crime Tour Trip, 9:00am – 3:00p**



March 2020

ADMINISTRATION AND FINANCE

Kyle Cratty, Director of Finance

- ◆ Auditors from Lauterbach and Amen were on site the first week of March to complete field work. Staff anticipate the report being presented to the Board in June.
- ◆ The District was awarded the Certificate for Excellence in Financial Reporting from the Government Finance Officers Association for the 2018 Audit.
- ◆ Staff is in the process of transitioning IT duties to Noventech and so far things are running smoothly.
- ◆ Staff is beginning work on converting the District’s dashboards to be compatible with Amilia.

Diane Stanke, Director of Marketing and Customer Service

- ◆ Work has begun on the IDNR Museum grant application to install geothermal at Pleasant Home.
- ◆ 2020 Census promotions continue.
- ◆ New pool rules signs are being developed for the 2020 pool season.

Tanya Fisher, Sponsorship Coordinator

- ◆ Rush Oak Park Hospital is partnering with the Park District to have their logo placed on the new windscreens at the Maple Park tennis courts.
- ◆ Gary Longstein is returning as a sponsor for the FLW Races and Kinetic Energy, a local electrical contractor, has signed on as a new sponsor.
- ◆ Potential summer guide advertisers, Day in Our Village, and Summer Concert sponsors are currently being secured.

Melissa Martinez, Communications and Marketing Manager

- ◆ The Spring 2020 Active Adult booklet was finalized and distributed to senior homes the week of March 9.
- ◆ The 2020 Ice Show program guides are being finalized to post on our website and to also have 100 free copies available to the public.

Scott Sekulich, Customer Service

- ◆ Scholarships used in January was \$6,163.89. This is about \$250 up from 2019.
- ◆ Below find our Childcare Discount Membership totals through February 29, 2020.

Tier	# Approved	\$ Saved
Tier 1 55%	45	\$9,638.20
Tier 2 40%	30	\$23,094.80
Tier 3 25%	39	\$8,131.75
	114	\$40,864.75

- ◆ Two memorial tree plaques have been ordered.
- ◆

- ◆ 199 welcome postcards were sent out to new residents of Oak Park covering the last two months of new residents.

Paula Bickel, Director of Human Resources

- ◆ New Hire Orientation – nine new employees attended.
- ◆ Recruiting for full-time General Maintenance Worker and Program Supervisor – Nature/Adventure.
- ◆ First Aid Training – thirteen employees attended.
- ◆ CPR/AED Training – eight employees attended.
- ◆ Paula attended PDRMA’s Training & Education Annual Committee Meeting.
- ◆

PARKS AND PLANNING

Chris Lindgren, Superintendent of Parks and Planning

- ◆ Ice Rink frames have been taken down for the season at Austin and Longfellow.
- ◆ Staff have been prepping, edging, and grading the baseball fields at Lindberg Park as field permits begin next week.
- ◆ Maple trees at Lindberg have been tapped for the collection of tree sap to make maple syrup.
- ◆ Reset wall at northwest corner of Barrie Park.
- ◆ Checked and cleaned inflatable movie screen.
- ◆ Welcomed new employee, James Mikucky.

Susan Crane, Cheney Mansion and Special Events

Special Events

- ◆ Winter Fest was held in Austin Gardens on February 8; turnout was not large and it was too warm for ice in the rink at Austin. While the crowd was small, those that came had fun. We are looking at next year and working with marketing on ideas to improve attendance through social media build up.
- ◆ Bands for summer concerts were finalized. With Day in Our Village slated for June 7, our first concert will be June 14, and run weekly thru August 23. Our summer movie schedule was also finalized with the first movie in Scoville planned for Sunday May 24.

Cheney Mansion

- ◆ February brought a number of successful adult programs to Cheney throughout the month including our second annual Adult Valentine’s Wine, Dine, and Dance which brought out 44 participants. Our popular Monday night dance instructors were on hand to teach lessons throughout the night. Dinner and open dancing with the DJ were also provided.
- ◆ Cooking and baking classes continue to fill and we had a local company return for their annual retreat again this year.
- ◆ Total rental revenue is running about 80% to budget through February. We do still have dates for weddings that people are interested in. Special Events and Corporate events are starting to come in.

Patti Staley, Director of Horticulture

- ◆ The Conservatory has welcomed 3,523 visitors the month of February, averaging 122 visitors a day.
- ◆ The Conservatory held eight children’s birthday parties during the month of February, celebrating with 134 kids. Nine rentals were held with 320 people.
- ◆ Ask a Master Gardener Help Desk helped seven visitors during February with plant care questions.
- ◆ A new Valentine’s Market was held on February 22, at the Conservatory. 267 people shopped the market in our greenhouses that featured blooming plants, bouquets, succulent heart gardens and more. Visitors sipped hot chocolate and cocoa while learning how chocolate is made in our Conservatory.

SPECIAL FACILITIES

Bill Hamilton, Superintendent of Special Facilities

Rink and Pool

- ◆ Ice bears had three teams win banners in their leagues for fall-winter 2019/2020 season! Peewee Navy earned 2nd place, Bantam Navy earned 1st Place, and Mite Navy earned 2nd place.
- ◆ Our 52nd Annual Ice Show has been postponed and is now scheduled to take place on May 29-31, 2020. There are 281 of our Skate School enrollees participating in the ice show compared to 270 in 2019. Staff worked hard to put the show together and prepare the building for the show. The skaters are excited to be able to demonstrate the skills learned through hard work in the skate school.
- ◆ Summer hiring is taking place for all positions, there is a record number of applicants. We are close to being fully staffed for cashiers, concessions, swim instructors, and camp counselors.
- ◆ Staff is working on planning and training for the new swim lesson program.
- ◆ Training for Certified Pool Operations (CPO), food handling certification, and safe driving are being planned for summer staff.
- ◆ Pool preparation has begun. Staff is working on refinishing Ridgeland locker room floors, emptying the diving wells, and starting on pool cleaning.

Jamie Lapke, Program and Operations Manager – Gymnastics

- ◆ The Oak Park Gymnastics Team Booster Club sponsored Cartwheel-A-Thon; 649 students participated completing 39,942 cartwheels. The fundraiser brought in \$5,204.79, before expenses. In the Staff Guessing contest of how many overall cartwheels will be performed, Coach Kirsna guessed 41,739.
- ◆ The Girls Team competed at Chicago Style in Chicago, IL; Level 8 and Level 4 got 3rd place.
- ◆ The Level 4 Boys Team competed at Perfect 10 Meet in Hanover Park.
- ◆ The Level 6+ Boys Team competed at Cereal City Meet in Battle Creek, MI; Level 6 got 1st place.
- ◆ The GIJO Boys Team competed at the Windy City Meet in Batavia; Level 4 got 2nd place.
- ◆ The Boys and Girls Teams competed at the Great Western Meet in St Charles, IL; girls Level 2 got 1st Place and boys Level 4 got 3rd Place.
- ◆ GRC Manager Jamie Lapke celebrated her 25th anniversary of employment with the District!
- ◆ The Xcel Girls competed at the Yurchenko Invite in Chicago, IL; Bronze Level got 1st place, Silver Level got 2nd place, and Gold Level got 2nd place.

Mike Loszach, Program Manager

School Age/Teens

- ◆ We competed in our first E-Sports event on Saturday, February 29, where our kids competed against kids from a neighboring Park District. We had two full busses of kids travel to the event and received positive feedback from kids and parents regarding the program.
- ◆ Camp Spark summer enrollment is off to a strong start. We already have more registrations in 2020 than we had in 2019 and our before camp option has seen a big increase in enrollment in 2020.

Early Childhood

- ◆ Mark your calendar for Screen Break: April 26-May 2. The community is coming together to provide free “screen free” activities to our residents.
- ◆ We are excited to offer our new Spanish preschool program at the revamped Carroll Center for the 2020-2021 school year. We have gotten very positive feedback from the community about this offering and enrollment is off to a strong start.

Nature/Adventure Programming

- ◆ The Park District is actively recruiting a new full-time staff member to supervise these programs. The previous staff member resigned from her position.

- ◆ We have a great expected turnout for our youth fairy gardens program on March 15, at the Conservatory. We have nine children registered to create their own fairy garden.

Arts/Special Interest/Active Adults

- ◆ Active Adult membership continues to increase surpassing the 200 mark!
- ◆ Ceramics registration has increased as we have offered a wider variety of classes in this area.
- ◆ Our Active Adult bridge group that meets on Wednesday continues to increase and has seen as many as 16 participants recently.

Chad Drufke, Recreation Program Manager

Fitness/Sports/Dance/Races

- ◆ Fitness participation in mind body software continues to show increase over last year in sales and attendance as of March 1.
- ◆ All three sessions of Summer Circus Camp are at or near capacity.
- ◆ The annual dance recital has key dates confirmed with picture day April 18, rehearsal May 1, and the recital taking place on May 2, at Fenwick High School.
- ◆ FLW race online registration went live on March 1.

Youth Sports

- ◆ The youth basketball season came to a close on Sunday, March 8, with championship day. Five teams were crowned winners of their respective leagues.
- ◆ Winter session youth sports classes are coming to a close. Spring classes will start in April outside on the fields.
- ◆ The spring youth T-ball league has a waitlist of 50 kids. We are doing our best to get all kids off the waitlist into what is becoming a popular program.

Adult Sports/Martial Arts

- ◆ All spring adult soccer leagues are full. We have a total of 26 teams participating in either the Sunday morning 11 on 11 league or the Thursday night 7 on 7 league.
- ◆ The spring pickleball program already has 28 participants registered for either the Wednesday night or Saturday afternoon offering.
- ◆ The winter adult volleyball league is heading towards the home stretch with playoff taking place the first week of April.

Memo

To: Kassie Porreca, Chair, Administration and Finance Committee
Board of Park Commissioners

From: Illiana De La Rosa, Finance Manager
Kyle Cratty, Director of Finance

CC: Jan Arnold, Executive Director

Date: March 13, 2020

Re: February 2020 Revenue Expense Report



Statement

Attached with this memo are the February Revenue and Expense reports. The two reports are the Revenue Expense Report by Fund as well as the Summarized Revenue Expense Report. The Revenue Expense Report by Fund provides detail by revenue or expense type by fund. The Summarized Revenue Expense Report includes a snapshot by area of overall revenues and expenses. The Health Insurance Fund is a non-operating internal service fund and to better reflect this difference it is split into a separate section on each report.

The February Revenue Expense Reports highlights include:

Summarized Revenue Expense Report

- Childcare Discount Memberships in the amount of \$40,865 has been awarded since January, offsetting revenue for childcare programming.
- Community Programs are performing well year-to-date and compared to last year due to strong Afterschool enrollments.

Revenue and Expense Report - by Fund

- Property tax receipts began in February, and will continue through March. Additional receipts expected in July and August.



February 2020 Revenue and Expense Report - by Fund

	<u>Operating Funds</u>										February Total	Budget YTD	Actual YTD	Prior YTD
	Corporate	IMRF	Liability	Audit	Recreation	Museum	Special Rec	Special Facilities	Capital Projects	Cheney Mansion				
Taxes	\$ 382,166	\$ 31,463	\$ 32,141	\$ 1,763	\$ 373,946	\$ 4,340	\$ 50,702	\$ -	\$ -	\$ -	\$ 876,521	\$ 1,492,442	\$ 876,521	\$ 1,347,091
Fees and Charges	\$ 12,944	\$ -	\$ -	\$ -	\$ -	\$ -	\$ -	\$ 78,572	\$ -	\$ 8,315	\$ 99,831	\$ 240,938	\$ 198,391	\$ 312,327
Intergovernmental	\$ -	\$ -	\$ -	\$ -	\$ -	\$ -	\$ -	\$ -	\$ -	\$ -	\$ -	\$ -	\$ -	\$ 40,038
Miscellaneous Income	\$ 86,245	\$ -	\$ 3,500	\$ -	\$ 400	\$ -	\$ -	\$ 6,345	\$ 350	\$ -	\$ 96,839	\$ 78,949	\$ 122,853	\$ 79,526
Sponsorship & Donations	\$ 1,545	\$ -	\$ -	\$ -	\$ 9,605	\$ -	\$ -	\$ -	\$ -	\$ -	\$ 11,150	\$ 16,262	\$ 19,798	\$ 12,500
Other Financing Sources	\$ -	\$ -	\$ -	\$ -	\$ -	\$ -	\$ 2,417	\$ -	\$ 363,004	\$ -	\$ 365,421	\$ 730,842	\$ 730,842	\$ 327,743
Program Revenue	\$ 510	\$ -	\$ -	\$ -	\$ 954,973	\$ -	\$ -	\$ 278,555	\$ -	\$ 4,970	\$ 1,239,008	\$ 2,048,623	\$ 2,132,578	\$ 2,058,494
Total Revenue	\$ 483,410	\$ 31,463	\$ 35,641	\$ 1,763	\$ 1,338,924	\$ 4,340	\$ 53,119	\$ 363,472	\$ 363,354	\$ 13,285	\$ 2,688,771	\$ 4,608,055	\$ 4,080,983	\$ 4,177,720
Wages	\$ 176,353	\$ -	\$ 4,943	\$ -	\$ 159,876	\$ -	\$ -	\$ 125,561	\$ -	\$ 8,218	\$ 474,951	\$ 1,047,794	\$ 785,783	\$ 755,931
Contractual Services	\$ 135,812	\$ -	\$ 122	\$ -	\$ 32,129	\$ 125	\$ -	\$ 25,913	\$ -	\$ 4,460	\$ 198,562	\$ 403,951	\$ 419,225	\$ 267,492
Materials and Supplies	\$ 30,872	\$ -	\$ 2,348	\$ -	\$ 10,114	\$ -	\$ -	\$ 23,902	\$ -	\$ 657	\$ 67,892	\$ 118,585	\$ 113,760	\$ 68,355
Benefits	\$ 34,868	\$ 26,155	\$ -	\$ -	\$ -	\$ -	\$ -	\$ -	\$ -	\$ -	\$ 61,023	\$ 130,533	\$ 121,717	\$ 100,024
Miscellaneous Expense	\$ 12,373	\$ -	\$ 7,431	\$ -	\$ 6,170	\$ -	\$ -	\$ 3,877	\$ -	\$ -	\$ 29,851	\$ 141,813	\$ 42,246	\$ 43,367
Debt Service	\$ -	\$ -	\$ -	\$ -	\$ -	\$ -	\$ -	\$ -	\$ -	\$ -	\$ -	\$ -	\$ -	\$ -
Utilities	\$ 22,206	\$ -	\$ -	\$ -	\$ 13,652	\$ 363	\$ -	\$ 18,951	\$ -	\$ 437	\$ 55,609	\$ 96,348	\$ 70,862	\$ 65,441
Other Financing Uses	\$ 56,990	\$ -	\$ -	\$ -	\$ 320,322	\$ -	\$ -	\$ 60,763	\$ -	\$ 2,098	\$ 440,173	\$ 880,345	\$ 880,345	\$ 468,936
Capital Projects	\$ -	\$ -	\$ -	\$ -	\$ -	\$ -	\$ -	\$ -	\$ 391,426	\$ -	\$ 391,426	\$ 336,667	\$ 404,457	\$ 19,279
Total Expense	\$ 469,473	\$ 26,155	\$ 14,844	\$ -	\$ 542,262	\$ 488	\$ -	\$ 258,967	\$ 391,426	\$ 15,871	\$ 1,719,486	\$ 3,156,036	\$ 2,838,397	\$ 1,788,825
Net	\$ 13,937	\$ 5,308	\$ 20,797	\$ 1,763	\$ 796,662	\$ 3,852	\$ 53,119	\$ 104,505	\$ (28,072)	\$ (2,585)	\$ 969,285	\$ 1,452,019	\$ 1,242,587	\$ 2,388,896
	<u>Non-Operating Funds</u>													
	<u>Health Insurance</u>	<u>February Total</u>	<u>Budget YTD</u>	<u>Actual YTD</u>	<u>Prior YTD</u>									
Taxes	\$ -	\$ -	\$ -	\$ -	\$ -									
Fees and Charges	\$ 11,752	\$ 11,752	\$ 24,442	\$ 23,940	\$ 22,424									
Intergovernmental	\$ -	\$ -	\$ -	\$ -	\$ -									
Miscellaneous Income	\$ 1,000	\$ 1,000	\$ -	\$ 1,000	\$ -									
Sponsorship & Donations	\$ -	\$ -	\$ -	\$ -	\$ -									
Other Financing Sources	\$ 72,653	\$ 72,653	\$ 149,503	\$ 145,307	\$ 141,193									
Program Revenue	\$ -	\$ -	\$ -	\$ -	\$ -									
Total Revenue	\$ 85,405	\$ 85,405	\$ 173,945	\$ 170,246	\$ 163,617									
Wages	\$ -	\$ -	\$ -	\$ -	\$ -									
Contractual Services	\$ -	\$ -	\$ -	\$ -	\$ -									
Materials and Supplies	\$ -	\$ -	\$ -	\$ -	\$ -									
Benefits	\$ 82,873	\$ 82,873	\$ 172,223	\$ 94,808	\$ 135,053									
Miscellaneous Expense	\$ -	\$ -	\$ -	\$ -	\$ 84									
Debt Service	\$ -	\$ -	\$ -	\$ -	\$ -									
Utilities	\$ -	\$ -	\$ -	\$ -	\$ -									
Other Financing Uses	\$ -	\$ -	\$ -	\$ -	\$ -									
Capital Projects	\$ -	\$ -	\$ -	\$ -	\$ -									
Total Expense	\$ 82,873	\$ 82,873	\$ 172,223	\$ 94,808	\$ 135,136									
Net	\$ 2,533	\$ 2,533	\$ 1,722	\$ 75,438	\$ 28,481									



February 2020 Summarized Rev Exp Report

PARK DISTRICT of OAK PARK

	<u>February-20</u>	<u>Budget YTD</u>	<u>Actual YTD</u>	<u>Prior YTD</u>
<u>Operating Funds</u>				
Corporate Fund				
100000 Administration				
Revenue	\$416,989	\$691,543	\$438,933	\$651,956
Expense	\$222,071	\$424,685	\$397,208	\$298,426
Net	\$194,918	\$266,858	\$41,725	\$353,530
10++35 Conservatory				
Revenue	\$7,787	\$0	\$14,106	\$21,682
Expense	\$33,313	\$61,935	\$45,815	\$34,916
Net	(\$25,526)	(\$61,935)	(\$31,709)	(\$13,234)
100050 Parks and Planning				
Revenue	\$58,634	\$14,201	\$65,964	\$50,015
Expense	\$214,089	\$360,964	\$347,035	\$263,315
Net	(\$155,455)	(\$346,763)	(\$281,071)	(\$213,300)
Total Corporate				
Revenue	\$483,410	\$705,744	\$519,003	\$723,653
Expense	\$469,473	\$847,584	\$790,058	\$596,657
Net	\$13,937	(\$141,840)	(\$271,055)	\$126,995
IMRF Fund				
150000				
Revenue	\$31,463	\$53,572	\$31,463	\$51,891
Expense	\$26,155	\$53,600	\$53,098	\$35,160
Net	\$5,308	(\$28)	(\$21,635)	\$16,731
Liability Fund				
160000				
Revenue	\$35,641	\$54,726	\$35,641	\$53,293
Expense	\$14,844	\$17,638	\$22,874	\$12,884
Net	\$20,797	\$37,088	\$12,767	\$40,409
Audit Fund				
170000				
Revenue	\$1,763	\$3,002	\$1,763	\$2,763
Expense	\$0	\$0	\$0	\$0
Net	\$1,763	\$3,002	\$1,763	\$2,763
Recreation Fund				
200000 Administration				
Revenues	\$383,951	\$656,308	\$390,516	\$556,812
Expense	\$381,027	\$794,572	\$730,210	\$366,676
Net	\$2,924	(\$138,264)	(\$339,694)	\$190,136



February 2020 Summarized Rev Exp Report

PARK DISTRICT of OAK PARK

	<u>February-20</u>	<u>Budget YTD</u>	<u>Actual YTD</u>	<u>Prior YTD</u>
200005 Communications				
Revenue	\$0	\$10,000	\$0	\$10,710
Expense	\$37,985	\$80,849	\$60,464	\$54,973
Net	(\$37,985)	(\$70,849)	(\$60,464)	(\$44,263)
20++51 Customer Service				
Revenues	\$0	\$0	\$0	\$0
Expense	\$29,938	\$60,488	\$51,286	\$50,260
Net	(\$29,938)	(\$60,488)	(\$51,286)	(\$50,260)
201025 Fitness				
Revenue	\$16,799	\$63,004	\$63,372	\$69,991
Expense	\$9,177	\$16,674	\$14,482	\$13,445
Net	\$7,622	\$46,330	\$48,890	\$56,546
201026 Youth Athletics				
Revenue	\$197,127	\$248,518	\$243,857	\$255,459
Expense	\$8,501	\$22,927	\$10,912	\$14,335
Net	\$188,626	\$225,591	\$232,945	\$241,124
201027 Adult Athletics				
Revenue	\$28,842	\$41,157	\$40,352	\$46,894
Expense	\$419	\$5,289	\$813	\$1,849
Net	\$28,423	\$35,868	\$39,539	\$45,046
201029 Teen				
Revenue	\$5,865	\$22,404	\$10,262	\$20,134
Expense	\$1,630	\$3,911	\$2,081	\$2,417
Net	\$4,235	\$18,493	\$8,180	\$17,717
201061 Community Programs				
Revenue	\$470,093	\$507,672	\$624,753	\$590,130
Expense	\$42,643	\$98,075	\$70,639	\$52,595
Net	\$427,451	\$409,597	\$554,114	\$537,535
201062 Fine Arts				
Revenue	\$177,394	\$336,300	\$223,665	\$197,411
Expense	\$10,410	\$19,662	\$14,606	\$13,314
Net	\$166,984	\$316,639	\$209,058	\$184,097



February 2020 Summarized Rev Exp Report

PARK DISTRICT of OAK PARK

	February-20	Budget YTD	Actual YTD	Prior YTD
201063 Early Childhood				
Revenue	\$58,854	\$163,249	\$139,906	\$183,311
Expense	\$20,532	\$55,043	\$35,981	\$38,771
Net	\$38,322	\$108,206	\$103,925	\$144,540
Total Recreation				
Revenue	\$1,338,924	\$2,048,611	\$1,736,682	\$1,930,852
Expense	\$542,262	\$1,157,489	\$991,474	\$608,634
Net	\$796,662	\$891,121	\$745,207	\$1,322,218
Museum Fund				
210000				
Revenue	\$4,340	\$7,389	\$4,340	\$7,177
Expense	\$488	\$6,506	\$655	\$16,971
Net	\$3,852	\$883	\$3,684	(\$9,795)
Special Recreation Fund				
220000				
Revenue	\$53,119	\$91,164	\$55,536	\$85,402
Expense	\$0	\$121,440	\$114,243	\$113,548
Net	\$53,119	(\$30,276)	(\$58,707)	(\$28,146)
Special Facilities Fund				
250000 Administration				
Revenue	\$0	\$0	\$0	\$0
Expense	\$73,464	\$150,282	\$135,002	\$114,805
Net	(\$73,464)	(\$150,282)	(\$135,002)	(\$114,805)
2519++ Pools				
Revenue	\$46,121	\$34,638	\$67,330	\$81,473
Expense	\$29,496	\$31,502	\$33,683	\$9,862
Net	\$16,625	\$3,135	\$33,647	\$71,611
2520++ Rink				
Revenue	\$229,049	\$516,975	\$423,721	\$513,092
Expense	\$28,273	\$96,322	\$51,786	\$48,193
Net	\$200,776	\$420,652	\$371,935	\$464,899



February 2020 Summarized Rev Exp Report

PARK DISTRICT of OAK PARK

	<u>February-20</u>	<u>Budget YTD</u>	<u>Actual YTD</u>	<u>Prior YTD</u>
2524++ Gymnastics				
Revenue	\$83,827	\$316,605	\$438,534	\$331,537
Expense	\$67,109	\$192,513	\$127,328	\$112,325
Net	\$16,718	\$124,092	\$311,206	\$219,212
2550++ Maintenance				
Revenue	\$170	\$450	\$340	\$660
Expense	\$59,526	\$114,034	\$86,695	\$72,760
Net	(\$59,356)	(\$113,584)	(\$86,355)	(\$72,100)
2557++ Concessions				
Revenue	\$4,305	\$5,293	\$5,791	\$4,959
Expense	\$1,098	\$2,940	\$1,764	\$2,039
Net	\$3,206	\$2,353	\$4,027	\$2,920
Total Special Facilities				
Revenue	\$363,472	\$873,960	\$935,715	\$931,721
Expense	\$258,967	\$587,594	\$436,257	\$359,983
Net	\$104,505	\$286,366	\$499,459	\$571,738
Capital Projects Fund				
700000				
Revenue	\$363,354	\$726,008	\$726,358	\$330,596
Expense	\$391,426	\$336,667	\$404,457	\$19,279
Net	(\$28,072)	\$389,342	\$321,901	\$311,317
Cheney Mansion Fund				
850000				
Revenue	\$13,285	\$43,880	\$34,483	\$60,373
Expense	\$15,871	\$27,519	\$25,279	\$25,709
Net	(\$2,585)	\$16,362	\$9,204	\$34,664
<u>Non-Operating Funds</u>				
Health Insurance Fund				
500000				
Revenue	\$85,405	\$173,945	\$170,246	\$163,617
Expense	\$82,873	\$172,223	\$94,808	\$135,136
Net	\$2,533	\$1,722	\$75,438	\$28,481

Memo

To: David Wick, Vice President, Parks and Planning Committee
Board of Park Commissioners

From: Jan Arnold, Executive Director

Date: March 12, 2020

Re: Architect and Engineering Services Contract



Statement

The Park District of Oak Park issued an RFP in 2015, for a feasibility study on a Community Recreation Center. The committee that reviewed and selected the firm was made up of one elected official from each of the six Oak Park government bodies. SinkCombs was selected to do this work in 2016. Lindsey Peckinpaugh was the principal on the project. SinkCombs was merged with Perkins and Will in 2017.

Discussion

Lindsey and her team have worked closely with the Park District of Oak Park over the past four years looking at various building layouts and cost options for a Community Recreation Center. Including, assisting the Park District with the recent PARC grant application.

The design and bid specification process needs to begin so that the Park District of Oak Park can 1) present the design plan to the Village of Oak Park's Plan Development Commission this summer and 2) be ready for bidding in January 2021, if required funding is secured. Staff recommend engaging Perkins and Will to serve as the lead architect for the Oak Park Community Recreation Center. Their proposal is attached with specifics regarding scope and sub-contractors.

Staff plan to begin working with Perkins and Will in April and to have project plans ready for bidding in January 2021. However, if the required funding is not secured, the Park District of Oak Park will wait for those funds. These bid specifications will be used regardless of the timing of the actual bidding process.

Conclusion

The Parks and Planning Committee recommend engaging Perkins and Will to serve as the architect on the Oak Park Community Recreation Center project along with their identified subcontractors: Terra Engineering, Altamanu, Larson Engineering and IMEG for a total cost of \$1,232,920 for the design, bid specification and construction oversight.

Attachment: Architect and Engineering Proposal

Park District of Oak Park Community Center

February 26, 2020 — Revised







Contents

Firm Profile — 6

Project Personnel — 18

Relevant Projects — 26

Scope and Fee Proposal — 34

Section 01.

Firm Profile

We believe that design has the power to make the world a better, more beautiful place.

That's why clients and communities on nearly every continent partner with us to design healthy, happy places in which to live, learn, work, play, and heal. We're passionate about human-centered design, and committed to creating a positive impact in people's lives through sustainability, resilience, well-being, diversity, inclusion, and research. In fact, Fast Company named us one of the World's Most Innovative Companies in Architecture. Our global team of 2,700 creatives and critical thinkers provides integrated services in architecture, interior design, landscape architecture, and more.



Areas of Practice

- Branded Environments
- Civic and Cultural
- Corporate and Commercial
- Corporate Interiors
- Health
- Higher Education
- Hospitality
- K-12 Education
- Landscape Architecture
- Planning and Strategies
- Science and Technology
- Sports, Recreation, and Entertainment
- Transportation
- Urban Design

**Most Innovative Companies
in Architecture 2018**

Fast Company

#2

Architecture Firm, 2019

*Architectural Record and
Interior Design Magazine*

Founded in

1935

Studios

25

Total Staff

2700+

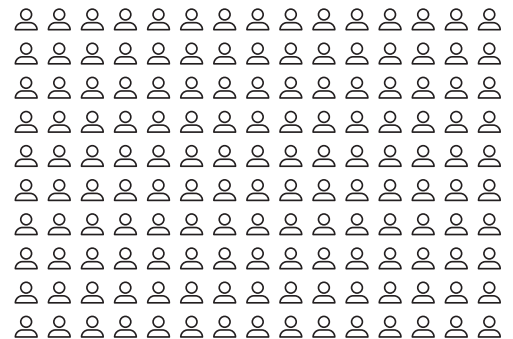

190 staff in Chicago Studio

Influencing the Future of Recreation

Areas of Expertise

Amphitheaters
Aquatics
Arenas and Event Centers
Clinical and Sports Performance
Collegiate Athletics and Training
Collegiate Recreation
Community Ice
Community Recreation
Equestrian and Fairgrounds
Mixed-Use Entertainment
Professional Athletics and Training
Stadiums

Disciplines

Architecture
Branded Environments
Interior Design
Planning and Strategies
Reuse and Transformation
Urban Design

Sports and Recreation

Participating in community or campus sports and recreation is a very local and communal experience. Each of our sports and recreation facilities are inspired by their locations, by their surroundings and by the unique culture and spirit of the community and institution that they serve. We design for the team, the spectators and those seeking both individual and social exercise. We seek to inspire with exceptional surroundings, quality construction, beautiful materials, views to the outdoors that together architecturally encourage the pursuit of personal wellbeing.

Recreation and aquatic centers play a variety of roles in a community. Not only do they promote physical activity for a number of diverse groups, but also encourage the development of social, professional and educational networks.

Our design begins with the aim to provide the setting for a diverse community to communicate across cultural boundaries, create new relationships, and foster lifestyle changes that help inspire and shape their lives.

In our communities, recreational venues offer active experiences that will last a lifetime. These facilities can provide various types of fitness activities, for all generations. We believe in this holistic view of wellness, and through our buildings we create important forums that are helping people improve their physical, mental and spiritual health. No longer simply a place to work out or learn to swim or skate, these facilities are integral to the everyday life of the entire community.



Right:
*Bison Ridge Recreation Center
Commerce City, Colorado*

Designing for life.

Sustainability

For nearly a quarter of a century, we've been at the vanguard of the sustainability movement. Passionate about designing places where human life can thrive and entire ecosystems flourish, we've developed a reputation for challenging the status quo.

Today, we're still at it. We're redefining sustainability as one of several interconnected parts to a greater, more meaningful whole. It's a philosophy we call Living Design. By seamlessly incorporating sustainability, resilience, regeneration, inclusion, and well-being into each of our projects, we can help sustain life on earth—today, tomorrow, and beyond.

Living Design

We envision designing a world that supports all forms of life, across all ecosystems. Informed by research, our projects endure, adapt, replenish the earth's resources, promote biodiversity, and help us all thrive.

High-Performance Buildings

We design buildings for maximum energy efficiency and optimal indoor environmental quality. Because we understand that human and planetary health are inextricably linked, and that buildings can have a major impact on both.

Transparency and Material Health

We ignited an industry movement toward healthy building materials in 2008. Today, we continue to lead a healthy materials crusade through focused research and knowledge sharing.

Carbon-Sequestering Timber Towers

The next frontier in sustainable design and construction? Engineered wood. We're expanding our knowledge of the promise and potential of timber as the urban building material of the future. And we're setting a global precedent for ultra-sustainable, carbon-neutral timber skyscrapers.



↑
More than a quarter of the materials used for Lucile Packard Children's Hospital Stanford were locally sourced.

←
A living green wall in the reception lounge of Madison Marquette in Washington, D.C lends a biophilic touch to the space.

We believe diversity drives innovation and inclusion sparks creativity.

Diversity and Inclusion

Different perspectives from people of different backgrounds paint a canvas of ideas with bolder, brighter colors. The combined creativity is infinite.

Together, we're designing a more vibrant, dynamic world. We're moving beyond socially constructed barriers and stereotypes and toward an open, united, productive society.

We're proud to lead our industry by example.

Our Diversity, Inclusion, and Engagement program supports and strengthens a firmwide culture that embraces and celebrates all people, regardless of age, culture, ethnicity, gender identity, language, physical ability, race, religion, sexual orientation, size, or socioeconomic status. Inclusion is paramount. Because when people feel included, they feel inspired and empowered. And that leads to innovation.

Our firm's people-first philosophy is built on three core principles:

1. Diversity

A diverse talent pool mirrors the diversity of our clients and communities, and ensures outside-the-box design thinking.

2. Inclusion

The inclusion of many voices—both within our firm and in the communities we serve—gives everyone the opportunity to contribute in a meaningful way. This leads to more enriched designs solutions.

3. Engagement

People who feel included are naturally more engaged, and engagement creates a sense of pride, ownership, and accountability.



Keeping ourselves accountable.

To make sure we uphold these principles in all aspects of our work, we established the design industry's first Diversity Council.

Led by our Director of Global Diversity Gabrielle Bullock, the Council is made up of a rotating cross-section of diverse staff from around the world. It's responsible for creating and maintaining a firmwide culture and set of business best practices that celebrate human differences.

Making A Difference: The Phil Freelon Fellowship

In partnership with the Harvard Graduate School of Design (GSD) and our colleague Phil Freelon, we offer a national fellowship for African American and other under-represented students. Introduced in 2016, the Phil Freelon Fellowship provides expanded academic opportunities to students of color, and helps fill the profession's talent pipeline with more diverse designers.





Company Overview



ABOUT TERRA

TERRA Engineering, Ltd. is a multi-disciplinary professional service firm, that utilizes our experience, intellect, passion, and diversity to serve our clients. Since 1992, our portfolio has evolved to include local, national, and global projects ranging in both type and scale. We approach our work from a foundation of comprehensive expertise and resources, allowing our disciplines to collaborate and create intelligently designed, thoughtful, site-specific solutions that skillfully balance aesthetic with function. We are dedicated to making our clients successful, and to enable our clients and staff to make innovative and socially responsible decisions that result in a sustainable and effective design.

MANAGEMENT TEAM

KAREN STEINGRABER
President

JAMIL BOU-SAAB
Executive Vice President

GEORGE GHAREEB
Vice President

ERIC THERKILDSEN
Associate Vice President

CHICAGO CONTACT

JAMIL BOU-SAAB, PE
Executive Vice President
225 W. Ohio Street, 4th Floor
Chicago, IL 60654 / 312.467.0123

SERVICE SECTORS

- Site Development
- Municipal Engineering
- Landscape Architecture
- Structural Engineering
- Bridge Inspections
- Geographic Information Systems
- Surveying
- Traffic Engineering/Studies
- Land Acquisition
- Construction Engineering
- Land Use Planning
- Transportation Engineering

MISSION STATEMENT

Our mission is to become the professional service firm of choice by empowering our employees to be innovative and socially responsible while achieving sustainable and profitable growth.

OUR PEOPLE

TERRA is an Equal Opportunity Employer with a staff of 80 employees of diverse ethnicities and backgrounds, including; Professional Engineers, Professional Traffic Operations Engineer, Structural Engineers, Professional Land Surveyors, Landscape Architects, GIS Analysts and LEED Accredited Professionals.

CERTIFICATIONS

TERRA is certified through more than a dozen agencies, and is a recognized WBE-certified company. Please contact us for more information regarding our various certifications.





Altamanu Inc. is a certified MBE/WBE/DBE Landscape Architecture, Urban Design and Planning firm based in Chicago, Illinois.

Josephine Bellalta and John Mac Manus, the principals of Altamanu Inc., share over 40 years of experience designing and building public spaces. Since founding Altamanu Inc. in 2000, Josephine and John have grown the studio into a 11-person design firm with landscape architects, arborists and soil specialists.

Altamanu specializes in the design of Public Open Space including parks, reserves, recreation elements such as athletic fields and artificial turf installations, institutional campuses, schools, healing gardens, as well as bike and multi-use trails, streets, roadways and bridges.

Altamanu has received national, regional and local awards for their work including:

ASLA Honor Award: Constructed Project, Grant Park Skate Park & Performance Space Chicago, IL

Green Award with PDOP for the Oak Park Conservatory Bio-Swale

Congress for New Urbanism Illinois Best Street: River Street Woonerf, Batavia, IL

The Community Service Award, for "Outstanding Contributions to the Community and State of Illinois" IPRA, IAPD, PDOP.

Josephine Bellalta may be contacted via telephone: 773-528-7492 or josephine@altamanu.com

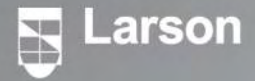

1979 Established	14 Offices Nationwide		Licensed Professional Engineers in all 50 States	Licensed in Mexico and 9 Canadian Provinces 3 Canadian Territories		100% Employee Owned	Over 200 Professionals
---------------------	-----------------------------	---	---	--	--	-------------------------------	-------------------------------------

Our History

From a small office in White Bear Lake, Minnesota, Larson Engineering has expanded to include 14 offices in 11 states. Our current President and CEO, Lee Granquist, was a young engineer at Larson when it opened with a handful of employees in 1979. Each office has its own story, but every office has grown for the same reason: dedication to meeting the client’s needs with innovative and cost-effective design. Our roots are in providing consulting engineering services to architectural and industrial clients. 1982 marked the beginning of Larson’s diversification in services with our entry into curtain wall engineering. We continue to expand our services to best serve our clients. Today, we are a trusted partner in each step of the design process. Larson’s structural, civil, process industrial, environmental, health & safety, oil & gas, mechanical, electrical and curtain wall engineers each have their own specialty. Whether it is the design of blast-resistant structures, slip formed silos or a biomass receiving and material handling system, we have the expertise to make your project a success. Our conscientious engineers guide clients toward the best solution for their unique needs. From the administrative assistant that answers your call, to the engineer assigned to your project and the accountant that sends the invoice – our whole team is made of employee-owners that are dedicated to client service.

Our Mission

Together we passionately use our engineering talents for the enhancement of our people, our communities, and our clients.

Our Shield

Around the office, we refer to our logo as our “shield.” To a structural engineer, the design would look familiar. It is based on the reaction, shear and moment diagram of a fixed-end span. While we have grown from our roots in structural engineering to offer other services, the shield reminds us of where we came from. It highlights one of the first concepts that a structural engineer learns. It is also a symbol of protection and an engineer’s responsibility to design in the interest of public safety. We’re not just designing a storage tank, a building foundation, stormwater drainage or a curtain wall façade. It’s about how these spaces can best serve the people that need them.

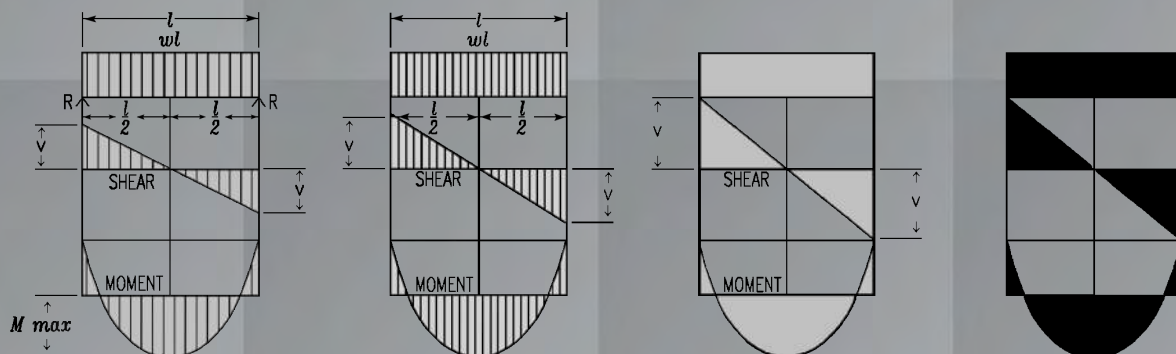

About IMEG



SPORTS & RECREATION FIRM OVERVIEW



UW Health Sports Factory, Rockford, IL

AT-A-GLANCE

- 100 Year Collective History
- Employee-Owned
- 1,500 Employees
- 50 Locations
- 400+ Licensed Engineers
- 125+ LEED AP's
- \$214 Million in Annual Revenue
- Top 10 Engineering Firm in U.S.

SERVICES

- Structural
- Mechanical
- Electrical
- Plumbing
- Fire Protection
- Technology
- Civil
- Survey
- Materials Testing
- Security
- Acoustics
- Architectural Lighting
- Commissioning
- Building Performance Analysis
- Building Certification
- Medical Equipment Planning
- Process Engineering
- Utility Infrastructure

With a history that dates back 100 years, IMEG grew from several firms coming together under one unifying vision: people-centered engineering. As a national engineering and design consulting company we've intentionally localized our focus to serve carefully chosen regions and markets, allowing us to put relationships and communities first, without sacrificing expertise.

Our specialties are high-performing building systems, infrastructure, program management and construction-related services, but our secret to success is found in our deep bench of nearly 1,500 team members and challenging ourselves to be thought leaders in the A/E/C industry.

Over the past few decades IMEG has built a strong reputation in the sports and recreation market. We understand sports arenas, stadiums, recreation and wellness centers require the coordination of virtually every engineering discipline to succeed. They are public facilities that must manage large crowds comfortably and efficiently. There are innumerable safety challenges, along with all the usual concerns for air quality, temperature and humidity control, acoustics and lighting. The difference IMEG brings is our innovative engineering design for high-performance sports and recreation facilities. We have engineered some of the largest venues from professional sports arenas and local civic centers to academic stadiums, recreation centers, natatoriums and outdoor sports complexes.

MARKET FACTS

- 150 sports & recreation clients
- 550 projects
- \$19 billion in construction

FACILITY TYPES

- Arenas
- Stadiums
- Ice Arenas
- Sports Complexes
- Parks & Recreation
- Gymnasiums
- Wellness Centers
- Natatoriums

Our portfolio includes more than 550 sports & recreation projects with more than \$19 billion in construction.

Section 02.

**Project
Personnel**

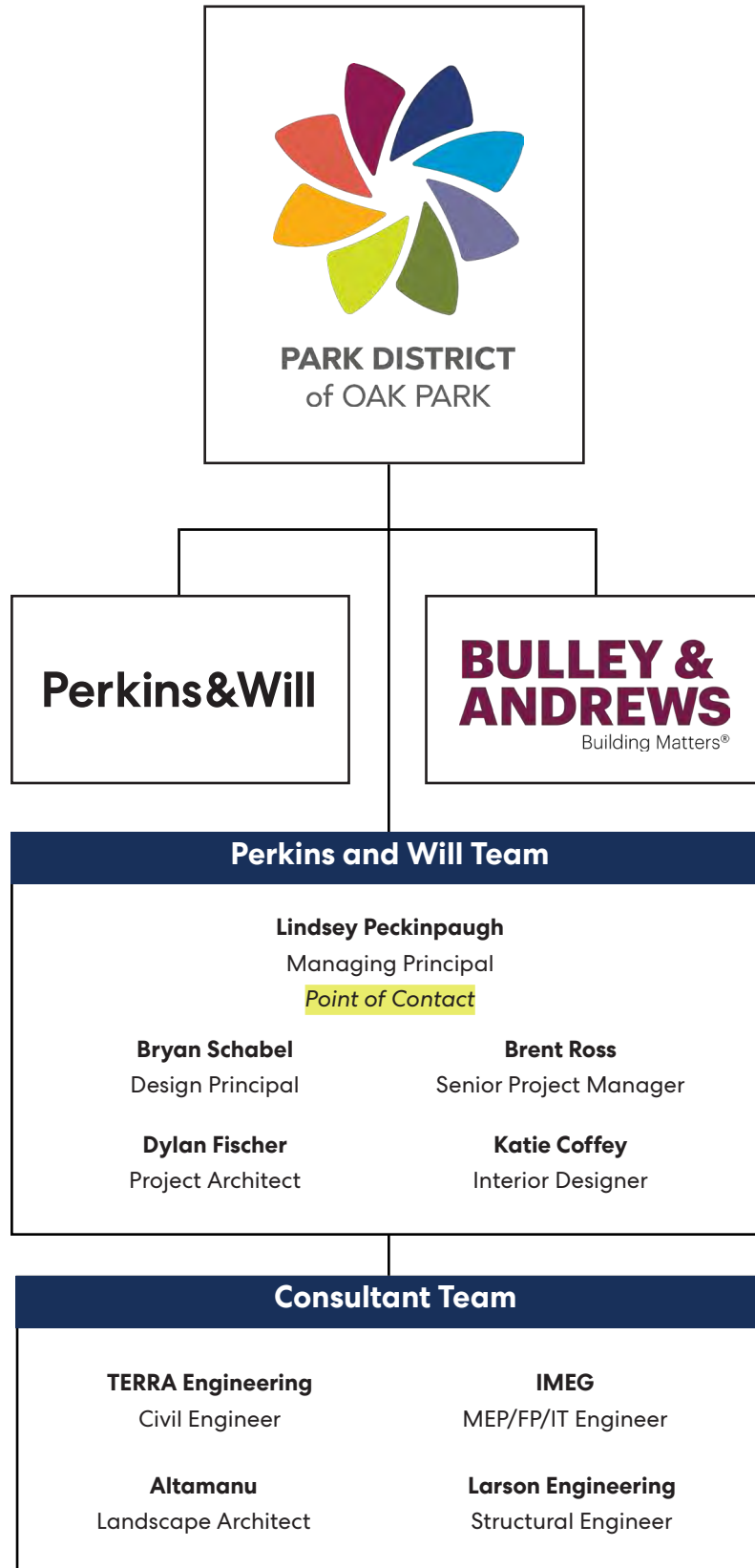

Lindsey Peckinpaugh, AIA, LEED AP®, RELi AP

Managing Principal, **Point of Contact**

“It’s about building relationships and strengthening communities” says Lindsey Peckinpaugh, Chicago’s Practice Leader for Sports, Recreation, and Entertainment. A natural consensus builder, Lindsey is a skilled moderator who excels at public outreach, stakeholder engagement, and building strategic framework for complex projects, both large and small. While the design and construction of projects is thrilling, Lindsey finds the greatest sense of accomplishment from the positive impact buildings have on their communities.

Although she grew up a competitive, multi-sport athlete, Lindsey did not intentionally set out to specialize in sports design. What drew her to the market was ultimately the communal nature of the work. Creating spaces where communities gather, recreate, cheer on their teams, and focus on their health. “It’s incredibly challenging, and also incredibly fun work!” says Lindsey.



Education

Bachelor of Environmental Design, Bachelor of Science in Architecture, Cum Laude
Ball State University

Registrations

Architect
Colorado (2004)

Architect
Illinois (2007)

Architect
Indiana (2013)

Architect
Wisconsin (2016)

Accreditations

LEED AP® BD+C
U.S. Green Building Council®

NCARB Certified
National Council of Architectural Registration Boards

RELI AP

Project Experience

Rockford Park District

- UW Health Sports Factory
 - Wedgbury Stadium Improvements
 - Riverview Ice House Expansion Study
 - Carlson Ice Arena Expansion Master Plan
 - Davis Park Master Plan
- Rockford, Illinois

West Chicago Park District

- ARC Recreation Center and Zone 250 Sports Performance Center
- West Chicago, Illinois

Pleasant Dale Park District

Walker Recreation Center Expansion Feasibility Study
Burr Ridge, Illinois

City of Columbus

Fair Oaks Mall Master Plan
Columbus, Indiana

Palatine Park District

Recreation Needs Assessment
Palatine, Illinois

Village of Lakewood

Sports Complex Plan
Community Center
Lakewood, Illinois

One City Center Mixed-Use Development

- PPL Center
 - Lehigh Valley Health Network Fitness Center
- Allentown, Pennsylvania

St. Charles Park District

- Recreation Center Feasibility Study
 - Comprehensive Parks Master Plan
 - Otter Cove
- St. Charles, Illinois

City of Goshen

Multi-Sport Outdoor Pavilion & Ice Rink Feasibility Study
Goshen, Indiana

City of Monroe

Multi-Sport Complex Study
Monroe, Michigan

Park District of Oak Park

Recreation Center Feasibility Study
Oak Park, Illinois

Marquette University

- Athletic Performance Research Center
 - Lacrosse Dome
 - Intercollegiate Athletics Facilities Master Plan
 - Al McGuire Center Renovation
- Milwaukee, Wisconsin

City of Bettendorf

Bettendorf Recreation Needs Assessment & Feasibility Study
Bettendorf, Iowa

West Cook YMCA

Feasibility Study
Melrose Park, Illinois

Saint Louis University

Hermann Stadium Improvements and Student Athlete Champions Center
St. Louis, Missouri

University of Notre Dame

Athletics Master Plan
Notre Dame, Indiana

City of West Lafayette

Wellness and Aquatic Center
West Lafayette, Indiana

Bryan Schabel, AIA, LEED AP®

Design Principal

Road trips were a favorite activity of the Schabel family. Bryan always loved setting off from his family's home in a small college town to visit new places, especially the national parks. However, it was their time spent in cities – both in the U.S. and abroad – that he enjoyed the most. When he was a teenager, Bryan's developer uncle offered him the opportunity to spend a few summers working for him in California. This solidified Bryan's interest in architecture and provided him his first industry experience.

Despite all his traveling as a kid, Bryan never really lived in a city until studying abroad in Rome. During that time, his eyes were opened to a design sensibility that continues to inform his work to this day. It's a sensibility grounded in an awareness of the permanence of architecture: fads are ever-changing, but authenticity is timeless – seek out the point where trend meets verity, and this is where you will find enduring style. This is Bryan's goal, to always look for the perfect balance between the current and the timeless.



Education

Bachelor of Architecture, 1995

Iowa State University,

Study Abroad Program, 1994

Iowa State University, Rome, Italy,

Registrations

Architect

Illinois

Accreditations

LEED AP®

U.S. Green Building Council®

Project Experience

Northwestern University

Ryan/Walter Athletics Center
Evanston, Illinois

William Jones College Preparatory High School

Chicago Public Schools /
Public Building Commission of
Chicago
Chicago, Illinois

Botanica

- Waterfront Botanical
Gardens Master Plan
- Educational Pavilion
Louisville, Kentucky

Chicago Children's Museum

Design Competition
Chicago, Illinois

Shanghai Natural History Museum

Shanghai, China

Pudong Youth Center

Competition Shanghai, China

Western Michigan University

South Neighbor Sub-Campus
Master Plan
Kalamazoo, Michigan

Bowling Green State University

Maurer College of Business
Bowling Green, Ohio

Northwestern University

- Segal Visitors Center and
Parking Garage
- Wirtz Center and Louis Hall
Facade Renovation
- Josephine Louis Theater
Facade Renovation
Evanston, Illinois

Northwestern University

Abbott Hall/RIC Feasibility
Study
Chicago, Illinois

Case Western Reserve University

Tinkham Veale University
Center
Cleveland, Ohio

Ewing Marion Kauffman School

Ewing Marion Kauffman
Foundation
Kansas City, Missouri

Lake Forest Country Day School

Lake Forest, Illinois

Chicago Department of Transportation

Damen Green Line Station
Chicago, Illinois

Brent Ross, AIA, LEED AP® BD+C

Senior Project Manager, Senior Associate

Brent believes in a client-centric design process that focuses on assessment, technology, and vision to bring value to our clients and community. He strives to create meaningful architecture that has a lasting impact on the people, places, and organizations involved. Brent also prides himself on his ability to listen and put the wants and needs of the client ahead of all other project criteria.

Always on the continuous learning path, Brent is eager to talk about the latest research for sleep, recovery, training, and nutrition. He's determined to find ways to help his client turn their athletes into true competitors; those willing to put in the work to achieve their goals. Likewise, Brent is willing to put in the work to make sure each of his projects reach their full potential.



Education

Bachelor of Architecture, 2006

Illinois Institute of Technology

Registrations

Architect

Illinois

Accreditations

LEED AP® BD+C

U.S. Green Building Council®

Project Experience

Rockford Park District

UW Health Sports Factory at
Rockford
Rockford, Illinois

West Chicago Park District

ARC Recreation Center
West Chicago, Illinois

City of Bettendorf

Bettendorf Recreation Needs
Assessment & Feasibility Study
Bettendorf, Iowa

Pleasant Dale Park District

Walker Recreation Center
Expansion Feasibility Study
Burr Ridge, Illinois

Palatine Park District

Recreation Needs Assessment
Palatine, Illinois

City of West Lafayette

Wellness and Aquatic Center
West Lafayette, Indiana

St. Charles Park District

Recreation Center Feasibility
Study
St. Charles, Illinois

City of Hutchinson

Hutchinson Sports Arena
Renovations & Additions
Hutchinson, Kansas

Beat the Streets

Wrestling Hall Concept
Chicago, Illinois

West Cook YMCA

Feasibility Study
Melrose Park, Illinois

Saint Louis University

- Hermann Stadium
Improvements
- Student Athlete Champions
Center
St. Louis, Missouri

Rutgers University

- Athletic Performance Center
- RAC Master Plan
- Athletics Master Plan
Piscataway, New Jersey

University of Northern Iowa

- UNI-Dome Renovation Study
- Dancer Hall Renovation
Cedar Falls, Iowa

University of Notre Dame

- Athletics Master Plan
- Harris Family Track & Field
Stadium Phase 1 and 2
- Rolfs Athletics Hall
- Joyce Center North Dome
Renovations
Notre Dame, Indiana

University of Illinois Urbana-Champaign

- Memorial Stadium Study
- Fighting Illini Baseball
Stadium Study
Champaign, Illinois

Oak Park, Park District

Community Recreation Center
Feasibility Study
Oak Park, Illinois

Dylan Fischer, AIA

Project Architect

Dylan's outstanding design skills will prove valuable to the project team. He recognizes the importance of interpreting and incorporating the needs and goals of the client and end-user groups as the most vital components in developing a successful facility.



Education

Master of Architecture

University of Cincinnati, Magna cum Laude, 2013

Bachelor of Science, Architecture

University of Illinois at Urbana-Champaign, Magna cum Laude, 2010

Registrations

Architect

Illinois

Project Experience

Oak Park, Park District Community Recreation Center Feasibility Study

Oak Park, Illinois

Rockford Park District Carlson Arctic Ice Arena Expansion

Rockford, Illinois

Rockford Park District Riverview

Ice House Study
Rockford, Illinois

St. Charles Recreation Center

St Charles Parks and Recreation District Feasibility Study
St. Charles, Illinois

UW Health Sports Factory at Rockford

Rockford, Illinois

West Chicago Recreation Center

West Chicago, Illinois

Fairfield University Alumni Stadium*

Fairfield, Connecticut

McKendree Metro Rec Plex and Twin Ice Facility

O'Fallon, Illinois

Saint Louis University

Hermann Stadium Renovation & Expansion
St. Louis, Missouri

University of Notre Dame

Joyce Center Renovation
South Bend, Indiana

University of Illinois Champaign

Illinois Field Improvements
Champaign, Illinois

**Completed prior to joining
Perkins and Will*

Katie Coffey, LEED GA

Interior Designer

Katie's diversified experience has been both in architecture and interior design. This has allowed her to develop the understanding that both the interior and exterior design of a building must work in tandem to develop successful results. She is passionate about interdisciplinary projects and has learned that working collaboratively with all members of a team will foster design solutions at every scale.



Education

Masters of Architecture

University of Nebraska

Bachelors of Architectural Studies

University of Nebraska

Accreditations

LEED GA

U.S. Green Building Council®

Project Experience

Aspen Dental Prototype

Chicago, Illinois

Mansueto Office

Chicago, Illinois

OCC

Chicago Expansion

Chicago, Illinois

Starbucks

Reserve Roastery

Chicago, Illinois

Waud Capital

Expansion

Chicago, Illinois

The Wrigley Building

Public Spaces

Chicago, Illinois

Fermilab National Accelerator Laboratory

Integrated Engineering

Research Center

Batavia, Illinois

The Paragon Chicago*

1326 S Michigan Ave

Chicago, Illinois

Aspire Residences*

211 S. Wabash

Chicago, Illinois

5252 Residences*

5252 S Cornell Ave

Chicago, Illinois

Drexel University*

The Summit at University City

Philadelphia, Pennsylvania

* Completed prior to joining Perkins and Will

Section 03.

Relevant Projects

Community Center Feasibility Study

Oak Park, Illinois

Client: Park District of Oak Park — **Size:** 60,000 square feet —

Completion Date: 2016 (study)

We were hired by the Park District of Oak Park to conduct a viability study for a new community recreation and aquatics center. Perkins and Will developed multiple program recommendations with market analysis and demand projections for the Park District Board's consideration and lead strategic partnership discussions for the newly proposed facility.

The final recommended program plan provides 107,000 square foot of new indoor recreation space for the District including the following:

- Indoor Walking Track
- Fitness Center
- Indoor and Aquatic Facilities
- Four Group Exercise Studios
- Three Gymnasiums
- Three Meeting Rooms
- Four Classrooms
- Activity Lounge
- Two Arts n Crafts Studios
- Child Sitting Center
- Indoor Walking Track
- Café



Aaniin Community Centre and Library

Markham, Ontario

Client: City of Markham — **Size:** 122,000 square feet — **Completion Date:** 2017 — **Sustainability:** Designed to achieve LEED® Gold certification — **Awards:** Interiors Award, Civic/Public, Contract Magazine, 2019; Best of Year Institutional, Interior Design Magazine, 2019; Institutional Wood Design Award, > \$15 M, WoodWORKS!, 2019; Facility of Merit Award, Athletic Business, 2019

The word Aaniin means welcome in Ojibwe, a fitting moniker that celebrates Markham's heterogeneous population. With 58% of its residents identifying as immigrants, Markham is one of the most diverse cities in Canada. To accommodate its varied citizenry, we worked to design a gathering place that could easily house multiple learning and recreational facilities under one roof.

Through an extensive public engagement process, the design creates new types of spaces from an open teaching kitchen to interactive maker spaces and a co-working studio that enable a community of newcomers to engage in new ways and to gain an important foothold within the local community and economy.

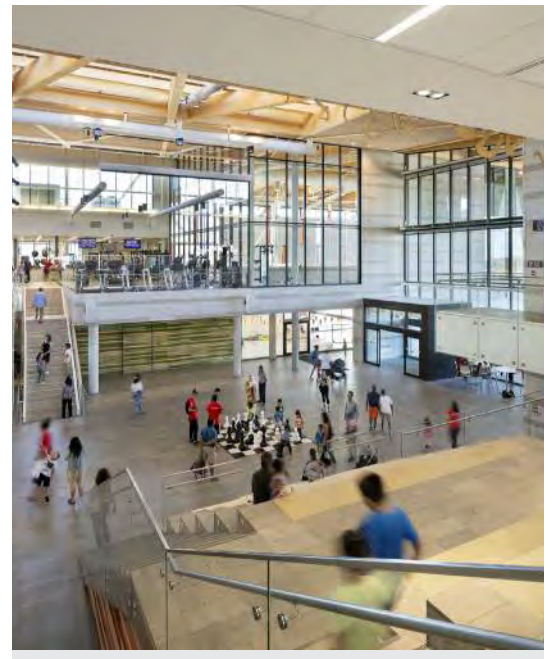

City of Commerce City Bison Ridge Recreation Center

Commerce City, Colorado

Client: City of Commerce City — Size: 106,000 square feet — Completion Date: 2018

With one foot rooted in the past and an eye toward the future, the citizens envisioned a building of timeless tradition in modern clothes. The center is a full-service community amenity providing programming for sport, social, and wellness opportunities. One of the biggest challenges was breaking down the scale of this large structure to a more pedestrian level, so the barns are rotated and split open to bring in daylight. The same character of materials leads patrons through the interior spaces with clear views to the activity areas: including a large community center for public events; a leisure pool with an interactive waterslide; a full service gymnastics studio; a large basketball and volleyball gymnasium; state of the art weight and cardio equipment; a technology lounge; and a number of group training opportunities, including an outdoor rooftop fitness deck with a stunning view of Long's Peak.

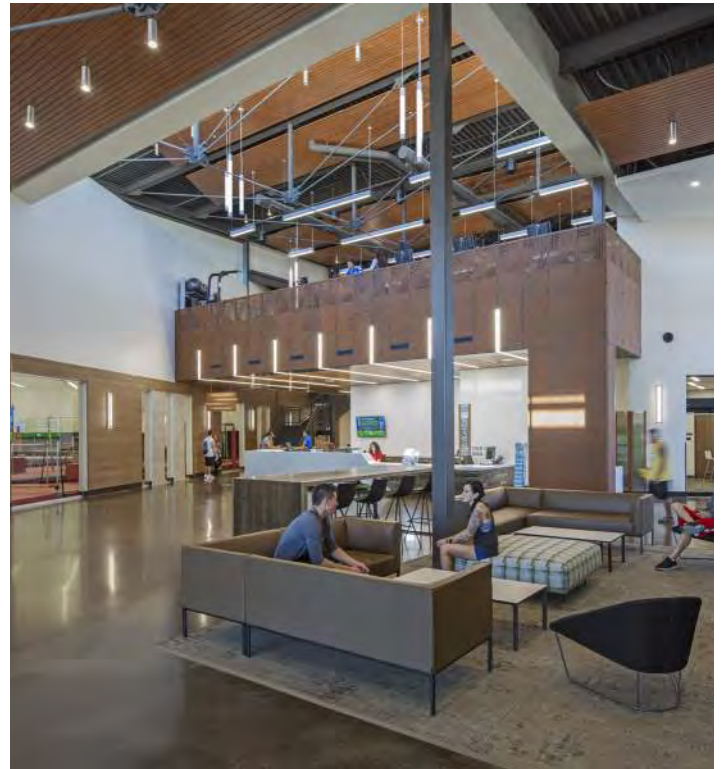

UW Health Sports Factory

Rockford, Illinois

Client: Rockford Park District — **Size:** 96,000 square feet —
Completion Date: 2016

In an effort to regain amateur sports tournament market share, the Rockford Park District, Rockford Area Convention and Visitor's Bureau, City of Rockford, City of Loves Park, and Winnebago County along with other area leaders developed a regional "Reclaiming First" initiative that aims to increase sports tourism. We (with sub-consultant Hunden Partners) were hired to complete a Feasibility Study for a downtown tournament facility at the edge of the Rock River. The study led to successful financing and project reality.

The UW Health Sports Factory project includes the redevelopment of an existing industrial building into a modern indoor sports complex. The facility will house basketball courts, volleyball courts, concessions, offices, meeting spaces, and a full-service restaurant with a 180-degree view over Rock River. The project also features site redevelopment with outdoor gathering space, parking and an extension to the River Walk.



The UW Health Sports Factory is one of the largest sports facilities in the Midwest. The facility is expected to draw over 500,000 people per year for basketball, volleyball, wrestling and pickleball tournaments, as well as trade shows, meetings and local user events.

West Chicago Park District ARC Center

West Chicago, Illinois

Client: West Chicago Park District

Size: 70,000 square feet

Completion Date: 2014

Our team was engaged by the West Chicago Park District to provide programming and design services for their new community recreation center. Located in Reed Keppler Park, the facility provides the community with new fitness and family-oriented amenities previously not available. We assisted the Park District with initial planning studies and ultimately recommended Reed Keppler Park as the project site for its ability to connect the Recreation Center with existing athletic fields, an outdoor aquatics park, a skate park and other recreational opportunities.

The West Chicago Park District opened the new 70,000 square foot ARC (Athletics, Recreation, Community) Center in the Fall of 2014, and has exceeded its pre-sale and initial membership expectations. Patrons praise the facility for its exceptional design, its location within the community and the number of amenities and options it affords, including:

- A multi-purpose, three court hardwood gymnasium
- A multi-activity gymnasium
- A walking/jogging track
- Event and party room rental spaces
- Food service support spaces
- A 7,800 square-foot fitness center
- Dance, aerobic and spinning studios
- An indoor playground and kids zone



West Chicago Park District Zone 250

West Chicago, Illinois

Client: West Chicago Park District

Size: 16,000 square feet

Completion Date: 2018



Perkins and Will was engaged by our long term client, the West Chicago Park District, to design a second facility within Reed Keppler park. Drawing on our experience from the successful ARC Center, we assisted the Park District through the successful application and award of an Illinois Department of Natural Resources PARC grant to partially fund the project.

The result is a 16,000 square foot indoor facility that provides two full size hardwood floor basketball courts that are easily converted for volleyball, baseball, softball, soccer, lacrosse, and other recreational projects. The facility hosts practices, games, tournaments, skill clinics, and community events.



City of West Lafayette, Wellness Center

West Lafayette, Indiana

Client: City of West Lafayette — **Size:** 73,000 square feet — **Completion Date:** Est. 2021, Currently Under Construction



Perkins and Will and MKSK were hired in 2016 to complete a Needs Assessment and Feasibility Study for West Lafayette, Indiana. Through a robust community engagement process, demographic and market analysis the team determined an unmet demand in the West Lafayette Community for a new indoor community wellness and recreation facility.

The West Lafayette Redevelopment Commission voted in early 2017 to move forward with the design of a new Community Recreation Center in Cumberland Park. With Perkins and Will as Architect of Record, and MKSK as Landscape Architect the team is now in the construction documentation phase of the project and has implemented innovative design solutions into the project plans such as:

- Inclusive Locker Room and Restroom facilities
- A Multi-purpose Activity Court
- A Hybrid recreational and lap pool featuring a vortex and zero-entry
- Potential partnership space

Section 04.

Scope and Fee Proposal

Perkins&Will

February 26, 2020 REVISED

Park District of Oak Park
Attn: Jan Arnold
218 Madison Street
Oak Park, IL 60302

Re: Request for Proposal Architectural & Engineering Services
Park District of Oak Park Community Center

Dear Jan:

On behalf of the Perkins and Will team I am pleased to offer our proposal for Architectural and Engineering Design Services for the Park District of Oak Park Community Center (The Center). Having completed the Feasibility Study with you, we are very invested in the success of this project. We understand your aspirational and functional goals for The Center and have a deep appreciation for your commitment to operational sustainability and careful stewardship of your community's resources. We look forward to collaborating with you and your selected Construction Manager to ensure that The Center maximizes its potential value for the Oak Park community. The following proposal reflects our understanding of the scope of the project and our team's services.

SITE LOCATION

Madison Street, between Harvey Avenue and extending west past Highland Avenue in Oak Park, IL.

SITE DESCRIPTION

The existing site consists of surface parking and is bisected by Highland Avenue, which will need to be vacated as part of this project. The Design Team will be responsible for leading this effort. The main entrance for the building will be located in the Northeast corner of the site and will preserve some open patio space for gathering. Phase I will occupy the portion of the site east of and including Highland Avenue while Phase II will occupy the remainder of the site west of Highland Avenue.

PROPOSED PROJECT

The Center is conceptualized to be a phased two-story, 48,780 SF multi-purpose community center. Phase I will feature a 2-court gymnasium with elevated running track, 2 group fitness rooms, a fitness center, community meeting rooms, a play zone, wellness center, and a single-level below-grade parking structure. Phase I will include enabling for the future construction of Phase II. Phase II will add

an aquatics facility that will include lap, leisure, and therapy pools. The Park District's goal is to make The Center a "green" facility. Sustainability goals will be established during early project planning.

PROJECT BUDGET

The anticipated budget for the project shall not exceed \$18,000,000.00 including financing cost. This includes Phase I of The Center, below-grade parking, and enabling for Phase II in the future. We have assumed a construction budget of \$15,642,778 for the building and site development. The remaining \$2,357,222 soft cost budget is estimated to cover design fees, construction phase testing, FF&E procurement, etc.

PROJECT SCHEDULE

Below is a preliminary project schedule identifying phase completion targets:

Notice to Proceed:	March or April 2020
Schematic Design:	Late June 2020
Design Development:	Late August 2020
Construction Documents:	Late December 2020
Bid:	January 2021
Groundbreaking:	April 2021

We look forward to collaborating with the Construction Manager to optimize the schedule and are comfortable delivering the project under the proposed schedule. Our fee includes considerations for two bid packages: an early utility package and a full building package.

CONTRACT TERMS

We propose a standard AIA Document B133-2014 contract for the project.

PROPOSED TEAM

Architect of Record:	Perkins and Will
Interior Design:	Perkins and Will
Code-required Signage:	Perkins and Will
Civil Engineering:	Terra Engineering
Landscape Design:	Altamanu
Mechanical/Plumbing Engineering:	IMEG
Electrical Engineering:	IMEG
Fire Protection (Delegated Design)	IMEG
Structural Engineering:	Larson Engineering
Audio Visual Design:	IMEG
Low Voltage IT Design:	IMEG

Access Control/Security Design:	IMEG
Geotechnical Services:	By Owner
Site (ALTA) Survey:	By Owner
Traffic Engineering:	By Owner
Construction Phase Testing:	By Owner

DIVERSITY GOALS

The following consultants are registered as MBE/WBE/or VBE firms by the State of Illinois. Our team's estimated participation percentage is 10.3%.

Civil Engineering:	Terra Engineering (6.3%)
Landscape Design:	Altamanu (4.0%)

SCOPE OF SERVICES

We have categorized our services in four ways: Basic Services, Included Additional Services, Available Additional Services, and Excluded Services:

Basic Services shall include architectural, civil, landscape, structural, and MEP engineering services for the following phases:

- Schematic Design
- Design Development
- Construction Documents
- Bidding and Negotiation
- Construction Administration
- Project Close-Out

Included Additional Services include the following and are reflected in our current proposed fees:

1. Programming: Our programming services will include a program confirmation phase in early schematic design to confirm the program established in the Feasibility Study. We will meet with the Steering Committee to confirm the program elements and define the final target building program based on the available project budget.
2. Multiple Preliminary Designs: During early schematic design our team will develop up to (2) preliminary exterior design concepts based on the confirmed building program. Upon review with the Steering Committee and Construction Manager, a single preferred planning strategy will be determined and developed for the final schematic design deliverable.

3. Building Information Modeling: The development and execution of a BIM Management Plan for the project which will outline the intended model use and how it will be shared with the Construction Manager, Owner, Vendors and building contractors. Architecture, MEP, and Structural disciplines will work within a BIM model for the project. Landscape Architecture and Civil will work in CAD. BIM services include modeling for the design and preliminary coordination of building elements and will aid in the generation of contract documents. Additional BIM goals and uses for the CM or Owner will be an additional service.
4. Civil Engineering: Our services will include civil engineering for the project site including the development of grading plans, utility service design within 5' of the building, subsurface drainage and storm water management, SWPPP plans, plaza, pavement, roadway curbing and pavement design, pavement markings, traffic control, curb ramps, and regulatory signage. Civil will also handle project permitting and entitlements. We will also include the application process associated with vacating Highland Avenue as part of Phase I.
5. Landscape Design: Our services will include landscape design services for the project site including perimeter building plantings, green roof, layout and design of all back of curb plazas, steps, rails, pavements, site grading and site amenities/furnishings (including benches, trash receptacles, bicycle racks), and locating and selection of site light fixtures.
6. Architectural Interior Design: Our interior design services will include the selection of all interior finish materials. We will propose multiple options and color palettes for review with the Steering Committee prior to final selections. Interior Design services will also include custom millwork design and coordination with specialty lighting and technology. We will include the design of all code required signage. Wayfinding and naming rights signage will be an additional service.
7. Value Analysis: Our team will work in collaboration with the Construction Manager to develop value analysis information on major project systems, such as, building primary structure, major MEP systems, building envelope (glazing and thermal insulation), and gymnasium equipment. We will provide the Steering Committee with Good-Better-Best options for review and approval on these systems. Third-party parallel cost estimating is available as an additional service.
8. Telecommunications/Data Design: The design of technology systems will include conduit and junction box rough-in for voice, data, Wi-Fi, cable television, and A/V systems. Final locations will be coordinated with the Owner, and A/V system components are to be provided and installed by the Owner.

9. Security Evaluation and Planning: The design of building security management systems will include conduit and junction box rough-in. Final locations will be coordinated with the Owner, and cameras are to be provided by the Owner.
10. Sustainability Goal Setting: We will lead the project team through a sustainability goal setting workshop during schematic design. We will identify sustainable strategies for the project and populate a LEED checklist for the project. We will implement and track sustainability goals throughout the project. If the Owner wishes to register the project for LEED or other program certifications, additional fees will apply.
11. Renderings: The development of up to (3) 3D renderings which reflect the updated Phase I design, materiality, and character of the project. The renderings will be updated during the Design Development Phase of the project. Our fee assumes (1) exterior entry view and (2) interior views updated from views provided during the feasibility study

Available Additional Services will include the following and are not reflected in the current proposed fees:

1. Sustainability Certification Programs: Should the City wish to pursue LEED, Fitwell, Well Building or other formal sustainability certification programs additional service fees will apply for project registration and administration.
2. Video Clips, Animations: Video clips, animations and virtual reality tours of the proposed facility design can be provided at an additional cost.
3. Enhanced Energy Modeling: Enhanced energy modeling can be provided as an additional service to the project.
4. As-Designed/As-Built Record Drawings: We will keep the BIM models/CAD files up to date as much as possible during construction with RFI, ASI, and Bulletin information. At substantial completion we will require that the Construction Manager provide an As-Built set of drawings and updated BIM models from their subs for incorporation into the As-Built record drawings. At project closeout, we will provide the Owner with a PDF set of As-Built drawings and all electronic drawings models/files.
5. Commissioning: As required by 2018 IECC, our team will provide code-compliant commissioning services that will include a commissioning plan, commissioning specifications, site observation and system verification checklists, functional performance testing for applicable systems, O&M manual review, and the development of a preliminary and final commissioning report.

6. Third-Party Parallel Cost Estimating: We will develop detailed cost estimates based on quantifiable take-offs at the end of the schematic design, design development, and 50% construction documents for comparison with the Construction Manager's opinion of cost. We will collaborate with the Construction Manager to come to a joint opinion of probable cost and identify for the Owner any discrepancies.

12. FF&E: We can provide additional fee to include the design, selection, and specification of moveable fixtures, furniture, and equipment (FF&E) for the project. This additional fee would include the selection of recommended pieces and specifying up to three vendors for bid.

Excluded Services include the following:

- Traffic studies
- Site survey and geotechnical services
- Construction materials testing
- BIM Modeling for the purposes of scheduling (4D, construction sequencing), fabrication, final coordination, and bills of materials
- Storm water analysis beyond the boundaries of the proposed site
- Design of utility improvements beyond the boundaries of the proposed site and/or those required to facilitate the vacation of Highland Avenue.
- Hazardous Material Analysis/Reports or Mitigation Design or Administration
- Services required by Authorities Having Jurisdiction that are either unwarranted or beyond the scope of this proposal
- Services in connection with change in government requirements instituted after the date of this agreement
- Services in connection with future facilities, systems, or equipment that are not intended to be constructed as a part of this project
- Off-site improvements such as lane widening to adjacent streets or extending utility or drainage mains to the site
- Engineering or coordination of regulated utilities
- Structural design or review of Contractor's construction systems or techniques such as formwork, excavations, shoring, bracing, or crane supports
- Services made necessary by contractor's default or by defects in the work of the contractor
- Special analysis such as blast resistance, defensive design (progressive collapse analysis), floor response for sound transmission, or vibration and dynamic analysis
- Performing the role of Special Inspector
- Electrical demand modeling
- Fire protection engineering design (beyond performance specifications)

PROPOSED FEES

We proposed the following fees:

The Center Construction Budget:	\$15,642,778
Perkins and Will	\$785,625
Terra Engineering	\$78,000
Altamanu	\$49,895
Larson Engineering	\$117,500
IMEG	\$201,900
Fee Subtotal:	\$1,232,920

The following is a breakdown of our proposed fees by phase:

Schematic Design (15%):	\$184,938
Design Development (20%):	\$246,584
Construction Documents (40%):	\$493,168
Construction Administration (25%):	\$308,230
Total Base Service Fees:	\$1,232,920

Reimbursable Expenses

Reimbursable expenses will be invoiced at our direct cost. We have proposed a note to exceed lump estimate for expenses for travel, printing, and communication.

Not to Exceed Reimbursable Limit \$23,000

Total Base Service Fee Plus Expenses:	\$1,255,920
--	--------------------

In regards to printing, this budget only includes printing of review sets during the design phases. It is anticipated that all bid sets, construction sets, addenda, bulletins, and submittal reviews will be issued via pdf, with those needing the drawings being responsible for the costs of printing. Reimbursable expenses will be invoiced at our direct cost.

Reimbursable Expense Rates:	
Mileage:	Per current IRS stipulations
Color printing/photocopying:	35 cents/8 ½ x 11
Black & white photocopies:	15 cents/8 ½ x 11
Large format photocopy:	As charged by printer
Photo reductions:	As charged by printer
Travel/lodging/food expenses:	Direct cost

Thank you for inviting us to submit our proposal. As you know, we are invested in the success of this project and we hope that you find our understanding of the scope of the A/E team's role commensurate with your expectations. Please keep in mind that the fees proposed within are preliminary in nature based on our understanding of the project scope, schedule, and delineation of roles. We are committed to providing you the highest level of service at very fair fees and welcome a detailed conversation based on the effort estimated and reflected within. I have always managed to negotiate fair fees with our clients and am confident we can do the same.

If you have any questions, please call me at 312-550-2396.

Sincerely,

Perkins and Will

A handwritten signature in blue ink, appearing to read "L. Peckinpaugh", with a large, stylized flourish at the end.

Lindsey Peckinpaugh
Managing Principal, Sports Recreation & Entertainment Practice Leader

CC: Brent Ross, AIA, Perkins and Will
Dylan Fischer, AIA, Perkins and Will

The Wrigley Building
410 North Michigan Avenue
Suite 1600
Chicago, IL 60611

Perkins&Will



Memo

To: David Wick, Vice President, Parks and Planning Committee
Board of Park Commissioners

From: Jan Arnold, Executive Director

Date: March 12, 2020

Re: CRC Construction Manager Contract



Statement

The Park District of Oak Park has used a variety of oversight methods for construction to include 1) owner working with General Contractor, 2) hiring an Owner Representative, and 3) hiring a Construction Manager. Each have met the agency's need based on the scope of the specific project. Staff are recommending that the Oak Park Community Recreation Center be built with the Construction Manager approach. This approach provides the architect upfront cost saving ideas, provide the owner an active partner to provide expertise, as well as knowledge of construction costs to ensure the project meets budget projections.

Discussion

Staff are recommending Bulley and Andrews to serve as the Construction Manager for the Park District of Oak Park. Bulley Andrews was the General Contractor for the Ridgeland Common Recreation Complex built in 2013-2014 which was completed on-time and on-budget. Bulley and Andrews recently served as School District 97's Construction Manager for the expansion projects at both Lincoln and Longfellow Elementary Schools. Additionally, they served as Construction Manager for the City of Evanston's Recreation Department on their ice arena and sport field project. Both D97 and Evanston had positive feedback about Bulley and Andrews' performance.

Timothy Puntillo, President, will serve as principal with assistance from Peter Kuhn. Both of these individuals were activity involved in the construction of the Ridgeland Common Recreation Complex. The design, cost estimating, bid specification, and permitting assistance is priced at \$67,960. The construction phase will be priced at 5.53% of the construction costs. This will include project oversight as well as bid solicitation from sub-contractors from all required trades.

Conclusion

The Parks and Planning Committee recommend engaging Bulley and Andrews to serve as Construction Manager on the Oak Park Community Recreation Center project for \$67,960 for the design and specification phase and 5.53% for the construction phase.

Attachment: Construction Manager Proposal



**BULLEY &
ANDREWS**
Building MattersSM

Park District of Oak Park

Recreation Center

PROPOSAL

Professional Construction Services

Presented by

Bulley & Andrews, LLC

1755 W Armitage Ave

Chicago, IL 60622

773.235.2433

www.bulley.com

February 11, 2020

Park District of Oak Park

Recreation Center

PROPOSAL FOR CONSTRUCTION MANAGEMENT SERVICES

February 11, 2020



Table of Contents

Section 1: Firm Overview.....	3
Section 2: Project Personnel	4
Section 3: Project Experience.....	7
Section 4: Construction Management Scope of Services.....	19
Section 5: Construction Manager Fee Proposal.....	24



Section 1: Firm Overview



Firm Overview

129 Years of Service



Established in 1891, Bulley & Andrews is one of the Midwest's oldest and most accomplished general contracting firms. Founded by Frederick Bulley, an English stonemason, and Alfred Andrews, an architect, the two men oversaw projects ranging from Chicago mansions to office buildings and industrial facilities.

B&A quickly established a reputation for on-time, on-budget construction. The standard of excellence set by Fred Bulley in the 19th century continues today and our motto remains "honesty, integrity, and service in construction."

More than 70 percent of B&A's work is from repeat clients, which serves as a testament

to our commitment to client satisfaction. We maintain long lasting relationships through dedication to quality workmanship and unparalleled attention to detail. Among the longest of these are The University of Chicago (since 1912) and The Northern Trust Company (since 1928). Our involvement with clients ranges from multi-phased, multimillion-dollar projects to on-going maintenance programs.

B&A has a regional focus and has been responsible for nearly \$3 billion worth of work during the past decade. Our systematic growth has been cited in Engineering News Record (ENR) where we are consistently listed among the nation's Top 400 Contractors, and in Crain's Chicago

“

Building relationships, building trust, is more important than bringing every dollar to the bottom line. And quality and workmanship are not just goals but a way of life at Bulley & Andrews.

Allan E. Bulley, Jr.
Executive Chairman

Business, where we are repeatedly named one of Chicago's 25 largest general contractors. Our annual volume is \$500 million.

Significant events in our more recent history include:

2016

Bulley & Andrews celebrates 125 years of building history, relationships and success. The firm moves into a new, 4-story building to serve as our new headquarters supporting our continued growth and investment in staff and technology.

2010

The firm acquired the assets of Takao Nagai Associates, a firm specializing in concrete restoration and waterproofing. Operating as a subsidiary of B&A, **Bulley & Andrews Concrete Restoration's (BACR)** concrete repair expertise

complements our extensive restoration experience.

2005

Bulley & Andrews established a subsidiary: **Bulley & Andrews Masonry Restoration, (BAMR)**. The group oversees and performs all services necessary to maintain, protect and preserve a building's exterior including inspection and analysis, masonry restoration, facade restoration, tuck-pointing, cleaning and sealing.

2004

Bulley & Andrews formalized a residential and restoration group which specializes in high-end residences and historical restoration. We have been involved

in myriad notable projects including the relocation of the Harriet Rees House and restoration of the Richard H. Driehaus Museum and Robie House. Our work has been featured in such high-end shelter publications as Architectural Digest, Elle Decor, Traditional Home and Veranda.

2003

Bulley & Andrews introduced Cleanroom technology to our host of services. Dedicated to the creation of contamination-controlled environments, this division provides a turnkey approach for these highly specializes spaces.

Capabilities



Markets

Through the years, B&A's staff and professional services have expanded to meet the needs and challenges of the building markets we serve including:

- Cleanrooms/Labs
- Commercial
- Corporate

- Educational
- Financial
- Healthcare
- High-End Residential
- Hospitality
- Industrial
- Institutional
- Retail
- Restoration
- Sacred Spaces
- Senior Living

Services

B&A provides a full range of services to manage the building process including:

- Preconstruction
- General Contracting
- Construction Management
- Design/Build

Self-Performance

B&A has the capability to self-perform the following trades with our field forces:

- Excavation
- Masonry Restoration
- Concrete Restoration
- Selective Demolition
- Concrete
- Carpentry
- Drywall



Allan E. Bulley, Jr.
Executive Chairman
BS, Brown University
63 years experience



Allan E. Bulley, III
Chairman & CEO
Bulley & Andrews
BA, Yale University
MBA, Northwestern
University
33 years experience



Tim Puntillo
President
Bulley & Andrews, LLC
BS, Purdue University
MBA, Northwestern
University
26 years of experience



Mark Evans
President, Construction
& Client Solutions
BS, Loyola University
37 years experience



Pat Healy
Vice President,
Business Development
BS, University of Maine
MS, Georgia Institute
of Technology
35 years experience



Mike Sudol
Chief Financial Officer
Vice President, Finance
& Administration
BS, Eastern Illinois
University
MBA, Loyola University
28 years experience

BULLEY & ANDREWS

1755 W. Armitage Avenue
Chicago, IL 60622 | 773.235.2433

OUR TEAM

Executive chairman, Allan E. Bulley, Jr., and chairman and CEO, Allan E. Bulley, III are the third and fourth generations, respectively, to lead Bulley & Andrews. Yet family pride and commitment to the firm extend far beyond ownership. Now in its 129th year, B&A employs a number of tradesmen whose families' relationships with the organization span generations, and include fathers, grandfathers, brothers and sisters, many of whom have been with B&A for 25+ years.

MANAGEMENT

Staff includes six members of executive management, nine business unit managers and approximately 80 project management/engineers and administrative staff, as well as 300+ field personnel.

Each member of our management team has a multi-dimensional background including academics, field operations, project management, and estimating. In the field, our experienced superintendents have backgrounds in the building trades.

SAFETY

B&A views safety and training as a top priority. We are proud of our excellent safety record, which is achieved through the dedication of our employees and our rigorous safety program.

Our Experience Modification Rate (EMR) is 0.72, among the

Personnel

Principals	6
Business Unit Leaders	9
Project Management	80
Estimators	4
Safety Specialists	4
Marketing/BD	4
Superintendents	50
Field Personnel	329
Support Staff	30

lowest in the industry and well below the nationwide industry standard (1.0). Our rating is important to owners because it decreases insurance rates resulting in direct cost savings.

FINANCIAL STRENGTH

For over a century Bulley & Andrews has maintained a conservative and fiscally sound approach to management. Our financial strength is evidenced by a relationship with the same banking institution for nearly 90 years, a net worth in excess of \$150 million, and a bonding capacity of \$750 million. Our Dun & Bradstreet rating is 4A2, the highest rating a company our size can achieve.

Classifications/Licenses:

- An Illinois Corporation; incorporated in 1906
- Chicago Contractor's License: TCG04239
- Ranked #209 on ENR's Top 400 Contractors List
- Contractors Score: 2405

Section 2: Project Personnel





Timothy Puntillo, LEED AP

With over 20 years of experience in the construction industry, Tim has expertly overseen the successful completion of numerous new construction, renovation, and restoration projects in nearly every building market. As president, Tim often serves as principal in charge, staying closely connected to project teams and providing executive oversight on value engineering, product and method selection, setup and mobilization, site safety and awarding of contracts. Tim has executive responsibility for all phases of construction and maintains a keen focus to ensure our clients' respective needs are fully understood and goals achieved. His client experience includes:

**PRESIDENT
BULLEY & ANDREWS, LLC**

Education
MBA; Northwestern University
BS; Civil Engineering
Purdue University

Tenure with B&A
24 Years

Client References
Mr. Mike Hudson
North Central College
Naperville, IL
630.637.5657

Mr. David Seleb
Oak Park Library
Oak Park, IL
708.697.6911

Architect References
Mr. Larry Kearns
Wheeler Kearns Architects
Chicago, IL
312.939.7787

Ms. Laura Young
Griskelis Young Harrell
Chicago, IL
312.645.0011

Mr. Eric Penney
Sheehan Nagle Hartray Architects
Chicago, IL
312.633.2900 X: 162

PARK DISTRICT OF OAK PARK

OAK PARK PUBLIC LIBRARY

FENWICK HIGH SCHOOL

ALCUIN MONTESSORI

CITY OF EVANSTON ROBERT CROWN COMMUNITY CENTER

COMMUNITY CONSOLIDATED SCHOOL DISTRICT 181

COMMUNITY HIGH SCHOOL DISTRICT 218

SCHOOL DISTRICT 97

GLENVIEW PUBLIC LIBRARY

CITY OF EVANSTON

ST. JOSEPH COUNTY PUBLIC LIBRARY

ARCHDIOCESE OF CHICAGO

BAHÁ'Í NATIONAL CENTER

ARGONNE NATIONAL LABORATORY

CHICAGO SHAKESPEARE THEATER

NOBLE NETWORK OF CHARTER SCHOOLS

CHICAGO INTERNATIONAL CHARTER SCHOOL



Peter Kuhn, LEED AP



As project executive, Pete leads the project team and is responsible for understanding and achieving the client's objectives. He will remain involved with the project from inception to completion providing continuity and single point of contact. Pete serves as the account manager and will address all staffing needs and direct all budgeting, scheduling and procurement and general administration of the Contract Agreement. He is renowned for his team approach to executing projects and ability to analyze and resolve technical issues. His project experience includes:

PROJECT EXECUTIVE BULLEY & ANDREWS, LLC

Education

BS; Construction Management
Ferris State University

Tenure with B&A 13 Years

Client Reference

Ms. Jeanne Keane
Oak Park Elementary School District 97
Oak Park, IL
708.524.3125

Mr. Lawrence Hemingway
City of Evanston
Evanston, IL
847.448.8267

Architect Reference

Ms. Jennifer Costanzo
STR Partners
Chicago, IL
312.464.1444

Mr. Brian Kronewiter
Cordogan, Clark & Associates
Chicago, IL
630.209.7525

CITY OF EVANSTON ROBERT CROWN COMMUNITY CENTER: EVANSTON, IL

- New, 6,000 sq. ft. branch library, with multipurpose and study rooms
- Two, NHL regulation-sized ice rinks with locker rooms
- Gymnasium space to accommodate two, full-court basketball games and designed for a wide range of sports activities including volleyball, indoor soccer, batting practice, and gymnastics
- Four-lane running track, fitness/dance room
- Preschool facility
- Administrative offices

PARK DISTRICT OF OAK PARK: OAK PARK, IL

- 50,000 sq. ft. renovation and addition to Ridgeland Common including pool, ice rink and fields

SCHOOL DISTRICT 97: OAK PARK, IL

- New, 38,000 sq. ft. Administration Building
- 11,000 sq. ft. Holmes Elementary School addition and renovation
- 2017 and 2018 life safety improvements at various elementary schools
- 16,500 sq. ft. Longfellow Elementary School addition
- 21,000 sq. ft. Lincoln Elementary School addition

NOBLE NETWORK OF CHARTER SCHOOLS: CHICAGO, IL

- First floor buildout, Rowe-Clark College Prep

NORTHWESTERN UNIVERSITY: EVANSTON, IL

- 44,000 sq. ft. renovation to Gleecher Center

FENWICK HIGH SCHOOL: OAK PARK, IL

- New, 330 space parking garage



Peter Kuhn is a recipient of Bulley & Andrews' 1891 Award. The award recognizes outstanding performance & exemplary client service.

Section 3: Project Experience



Experience in Oak Park & River Forest

Bulley & Andrews is highly familiar with Oak Park and its subcontractor community. The knowledge gained from our extensive portfolio in the area (see list below) gives us a distinct advantage during the subcontractor selection process. It enables our team to generate interest from quality subcontractors and make the best decisions based on the project and the owner's needs and goals.

Bulley & Andrews has a vested interest in cultivating our positive reputation in a community that has appreciated our quality workmanship and stewardship mentality.

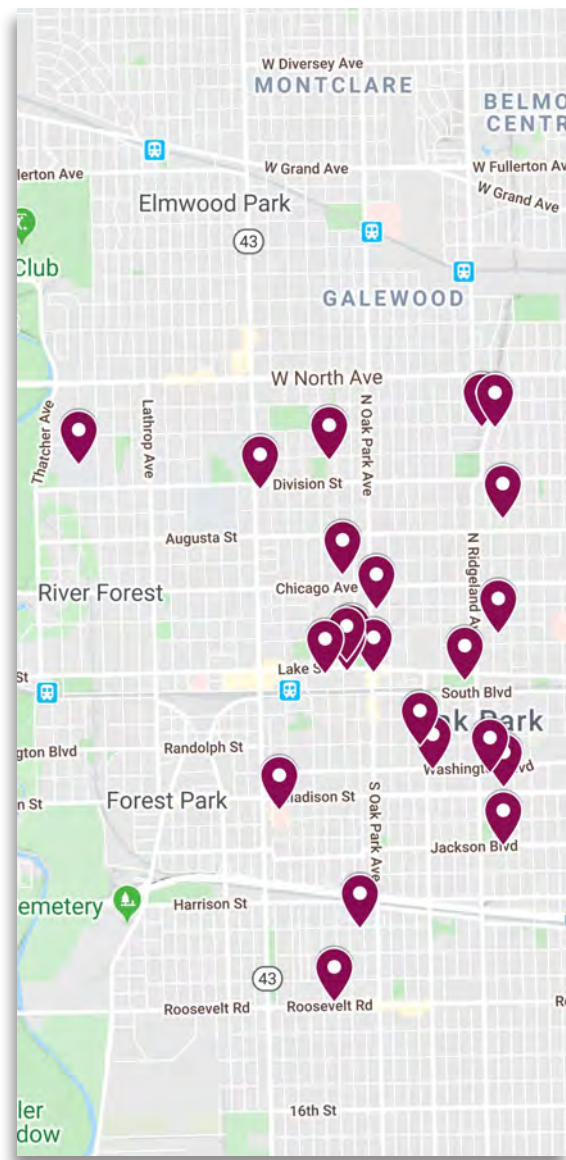

**Dominican University
Rebecca Crown Library
Renovation**

7900 W. Division St.

**School District 97
Renovation**

260 W. Madison St.

**Oliver Wendell Holmes
School Renovation**

508 N. Kenilworth Ave.

**United Lutheran Church
Renovation**

409 Greenfield St.

**Park District of Oak Park-
Ridgeland Common**

415 Lake St.

**Oak Park Public Library
Renovation**

834 Lake St.

**First United Methodist
Church of Oak Park**

324 N. Oak Park Ave.

**Robert Morris University
Eyre Cafe**

128 N. Oak Park Ave.

**Rush Oak Park Hospital
Pharmacy**

520 S. Maple Ave.

**Unity Temple
Renovation**

875 Lake St.

**Midtown Athletic Club
Renovation**

1135 N. Harlem Ave.

**First United Church of Oak
Park**

848 Lake St.

**Calvary Memorial Church
Renovation**

931 Lake St.

**Beye Elementary School
Renovation**

230 N. Cuyler Ave.

**Hatch Elementary School
Renovation**

1000 N. Ridgeland Ave.

**Horace Mann
Elementary School
Renovation**

921 N. Kenilworth Ave.

**Percy Julian
Middle School Renovation**

416 S. Ridgeland Ave.

**Whittier Elementary School
Renovation**

715 N. Harvey Ave.

**Longfellow Elementary
School Addition**

715 Highland Ave.

**Lincoln Elementary School
Addition**

1111 Grove Ave.

**Alcuin Montessori School
Addition and Renovation**

6932 Roosevelt Road

**Fenwick High School
Renovation**

505 Washington Blvd.

**Good Shepherd Lutheran
Church**

611 Randolph St.



**415 LAKE STREET
OAK PARK, ILLINOIS**

Project

Ridgeland Common renovation

Role

Construction Manager

Owners Representative

Project Management Advisors, Inc.
(PMA)

Architect

Nagle Hartray Architecture

Park District of Oak Park

The Park District of Oak Park provides recreational facilities and services for 53,000 residents. To assist the Park District in their continued commitment to residents, Bulley & Andrews provided construction management services for renovations to Ridgeland Common.

To create the new recreational space, the existing building went through a major 54,000 sq. ft. renovation and expansion. All components were removed except for the existing wood timber structure. The ice rink was expanded to official size and equipped for year round use and all interior facilities were entirely updated. Additional modifications on the six acre site include:

- 50 meter swimming pool update
- New children's zero-depth play pool
- Additional fencing and lights for the ball fields
- Two baseball fields / One soccer field - new synthetic turf
- New 10,000 sq. ft. dog park
- New parking lot

The project achieved LEED Gold certification.



**1701 MAIN STREET
EVANSTON, ILLINOIS**

Project

New Community Center, Ice Complex
& Library

Owner

City of Evanston

Role

Construction Manager

Architect

Woodhouse Tinucci Architects
MacLennan Jaunkalns Miller
Architects

Robert Crown Community Center, Ice Complex and Library

Originally built in 1974, the Robert Crown Center has long served as a social and recreational hub for the City of Evanston. Experiencing a number of functionality-related issues, this resource no longer meets the growing needs of the community.

To continue providing innovative programs and services in a safe and modern environment, the City of Evanston is building a new Robert Crown Community Center, Ice Complex & Library. Bulley & Andrews is currently serving as construction manager for the project. The new center will include:

- 6,000 sq. ft. branch library, with multipurpose and study rooms
- Two, NHL regulation-sized ice rinks with locker rooms
- Gymnasium space to accommodate two, full-court basketball games and designed for a wide range of sports activities including volleyball, indoor soccer, batting practice, and gymnastics
- Four-lane running track
- Fitness/dance room, large enough to accommodate 15-20 people
- Preschool facility
- Administrative offices

The project is anticipated to achieve LEED Silver certification.



Projects

New Administration Building

2-story addition to Holmes Elementary

Addition, renovations and life safety upgrades to Lincoln Elementary

Addition, renovations and life safety upgrades to Longfellow Elementary

Role

Construction Manager

Architect

STR Partners

School District 97

Oak Park School District 97 selected Bulley & Andrews as construction manager for multiple projects throughout the district. Projects include the new administration building 11,000 sq. ft. addition to Holmes Elementary School and life safety improvements across the district. Much of the scope of work at the elementary schools focuses on create new and better spaces for increasing enrollment including

- New classrooms
- Expansion of the multipurpose room
- Renovation of the library facilities
- New STEM Lab
- Creation of additional small group instructional spaces
- Renovation of existing classrooms to meet the districts “21st Century Learning” initiatives
- Creation of new gardens and play areas

Most recently, B&A served as construction manager for two new addition and renovation projects, one at Lincoln Elementary and the other at Longfellow Elementary. The facility improvements enabled SD97 to effectively meet the needs of the growing student population, while also providing flexibility should the school’s projected enrollment require additional changes.



**6942 ROOSEVELT ROAD
OAK PARK, IL 60304**

Project
Addition and renovation

Role
Construction Manager

Architect
Tom Brock Architects
Eight Cubed architecture

Alcuin Montessori School

Bulley & Andrews provided construction management services for Alcuin Montessori School's much needed expansion to accommodate their growing infant, toddler and middle school program.

Located in southwest Oak Park, the school's new 10,000 sq. ft. campus includes a new addition and renovation to an exciting building. The project has created an inspiring environment, including classrooms and play space. The second campus enhances the Montessori mission to allow children learn at their own pace, provide activities designed to develop more than academic skills and cultivate a life-long love of learning.



Scott McDonald © Hedrich Blessing

**834 LAKE STREET
OAK PARK, ILLINOIS**

Project

New public library

Role

Construction Manager

Architect

Nagle Hartray Architecture

Oak Park Public Library

Oak Park Public Library looked to Bulley & Andrews to serve as construction manager for the village's new \$19.6 million, three-story public library. Located at the corner of Lake Street and Grove Avenue, the facility is 140,000 sq. ft. and includes a tech center, café, art gallery, and public meeting rooms, in addition to traditional library facilities.

The south elevation is faced with stone while the east elevation, adjacent to Scoville Park, features copper panels and is topped with an undulating roof. The library's second and third floors feature large windows providing patrons with a generous view of the park. The facility also includes underground parking for 80 cars.

The project was the recipient of the Chicago Building Congress Award of Merit.



**100 S GARFIELD ST.
HINSDALE, ILLINOIS**

Project
New Hinsdale Middle School

Role
Construction Manager

Architect
Cordogan, Clark & Associates

School District 181

Hinsdale Middle School students now have a new, 141,500 sq. ft. state-of-the-art facility dedicated to active and collaborative learning.

The new school, designed by Cordogan Clark and constructed by Bulley & Andrews, features 28 core classrooms; six science laboratories; 10 resource small classrooms; a 15,000 sq. ft. gymnasium; a cafetorium; full-service production kitchen; large band, orchestra and choral rooms; music ensemble practice rooms; faculty offices; a media resource center and Maker Space; fine arts laboratory; ceramics kiln; outdoor classroom with projection surface; and a green roof.

At the heart of the school is a three-story sky-lit atrium. Filled with natural light, the atrium connects the school's main common spaces. Providing a welcoming and engaging environment throughout the school, large windows provide generous natural light and collaborative spaces foster engagement and community.



**6100 S COTTAGE GROVE AVE
CHICAGO, ILLINOIS**

Project

New athletic facility

Role

Construction Manager

Architect

Nagle Hartray Architecture

MetroSquash

Hyde Park based nonprofit organization MetroSquash is now able to realize their vision to become a Chicago leader in promoting academic achievement, healthy lifestyles, and access to opportunity for youth with their new, 21,000 sq. ft. facility in Woodlawn. Located just around the corner from the University of Chicago's campus, the precast structure includes seven squash courts, one doubles court and four classrooms.

The new MetroSquash Academic & Squash Center allows MetroSquash to double the number of children in its after-school lessons and summer programs to 300 from 150. The organization utilizes the racket sport, Squash, to help Chicago Public School students with athletic and academic performance.

Municipal Experience

From city halls to community centers, municipal buildings are central to how our communities live, gather and grow.

Though needs vary by building type and project scope, two things are steadfast: municipal structures must serve multiple constituencies and need to be extremely durable.

In addition to selecting the best materials and subcontractors for the project, Bulley & Andrews' team evaluates the lifecycle costs associated with maintaining and operating facilities. This information is vital to helping Owner's make decisions that positively impact a building's life expectancy. The results ensure the building meets the goals of the end-users as well as the expectations of the community at large.



Cicero Municipal Complex

City Hall
Police Headquarters
Youth Center
Parking Garage



City of Elgin

Spring Street concrete repairs

City of Evanston

New Levy Senior Center
Three parking garage renovations
Robert Crown Community Center, Ice Rink and Library Complex



City of St. Charles

River wall and plaza restoration



Community Consolidated School District 181

New Hinsdale Middle School



Community High School District 218

Harold L. Richards High School addition and remodeling

Decatur County

Decatur County Courthouse masonry restoration

Deerfield Police Station

Roof truss replacement

Glenview Public Library

New public library and parking garage

Municipal Experience Cont'd



Hanover Park Public Library

New public library

Mt. Prospect Public Library

Public library addition and renovations

Oak Park Public Library

New public library

Parke County

Parke County Courthouse masonry restoration



Park District of Oak Park

Renovation of Ridgeland Common including Paul Hruby Ice Arena

Schaumburg Township Library District

New Hanover Park Public Library



Skokie Park District

Weber Center Skatium renovation

Tippecanoe County

Tippecanoe County Courthouse masonry restoration



Village of Northfield

Village Center and police station renovation

Village of Schiller Park

Accessibility upgrades
Exterior renovations



Wheaton Public Library

Public library addition and renovations

References

ALCUIN MONTESSORI SCHOOL

Ms. Gina Gleason
Executive Director
Oak Park, IL
708.366.1882

OAK PARK PUBLIC LIBRARY

Mr. David Seleb
Executive Director
Oak Park, IL
708.697.6911

OAK PARK SCHOOL DISTRICT 97

Ms. Jeanne Keane
Sr. Director of Buildings & Grounds
Oak Park, IL
708.524.3125

PARK DISTRICT OF EVANSTON

Mr. Lawrence Hemingway
Director of Parks, Recreation and
Community Services
Evanston, IL
847.448.8267

**CORODOGAN CLARK &
ASSOCIATES**

Mr. Brian Kronwitter
Executive Vice President
Auroria, IL
630.209.7525

FENWICK HIGH SCHOOL

Mr. Matt McNicholas
Facilities Advisory Committee Chair
MGLM Architects
Chicago, IL
312.588.4109



At the conclusion of our project, it is gratifying to look back and know that the absolute best decision was made when the library trustees chose Bulley & Andrews to be the Construction Manager for our project.

Ms. Vickie Novak
Glenview Public Library



Section 4: Construction Management Scope of Services



Scope of Services

Construction Management Approach

As construction manager, Bulley & Andrews (B&A) will work as an extension of the Park District of Oak Park staff, offering a hands-on, detail oriented approach to your building program.

Our approach is rooted in partnership with all stakeholders. In doing so, we aim to foster and promote a team-oriented building process. In other words, we view ourselves as a partner to cultivate creative problem-solving, promote value management and follow a “one for all, all for one” philosophy. This approach leverages the expertise and knowledge of the entire team which optimizes and delivers the greatest value.

Following is an overview of our services:

PRECONSTRUCTION

Every project, regardless of the size or scope, has specific objectives, special nuances and unique challenges. That’s why preconstruction is such an important part of the construction process. A strong preconstruction effort is central to charting the course for a project’s overall success.

Bulley & Andrews’ (B&A) preconstruction process is collaborative, iterative and laser-focused on providing our clients with the most accurate data to inform decisions. B&A’s proactive, solution-driven mindset directs us to apply our efforts to not only identify problems, but to develop and recommend solutions as early as possible. This approach ensures owners receive the most value for their program dollar.

Before our first budget is prepared, the entire project team will meet, become acquainted with, and discuss, what is most important about the project. This establishes what we refer to as conditions of satisfaction (COS). This set of parameters will be our guiding light when it comes to executing decisions and moving the project forward.

In order to drive the preconstruction and construction schedule, we utilize pull planning to establish a



The pull planning process promotes accountability, camaraderie and a shared mission for the project.

network of commitments from the design team, owner and B&A. The pull planning effort, will help us determine key steps in the design process, including:

- Where critical decisions will need to be made
- Establish milestones for design packages/charettes for pricing
- Constructibility evaluation
- Major budget deliverables

Each week we will measure the completion of each activity to hold one another accountable. Pull planning breaks down the project into smaller phase pulls, and the trades work together to develop a plan for the next six weeks. That plan is updated weekly. This allows the team to find efficiencies if activities are going well or help solve problems if issues are identified. Pull planning is an effective tool that begins in preconstruction and helps drives success through construction.

During schematic design, we will identify opportunities that may exist relative to different

systems, assemblies and material selections. These efforts are to optimize the teams' efforts and maximize project cost, schedule and quality. Next, we set the target value for the project through detailed assumptions, historical cost data and trade budget recommendations. We also encourage open communication with the design partners so that we can provide, input on the initial design intent. We want to leverage our depth of construction experience as well as our trade partners' expertise.

Early engagement of major trades is key. Trade input and assistance during early design efforts incorporates constructibility into the work flow, in lieu of making it the 'last stop' in the design process. This happens through face-to-face scope and budget discussions with our trade partners and the project team. Doing so, we are able to better develop overall design details based on the most relevant and successful methods in the marketplace. This will help drive 'certainty of outcome' earlier in preconstruction, as opposed to a frustrating design (in a vacuum), budget, VE, redesign process. In other words, before design is put to paper, we bring all of the experts to the table – engineers, architects, manufacturers and installers – to collaborate on the best possible outcome for the project.

Additionally, B&A will drive value management by providing the team options through 'choosing by advantages'. This process can be performed on a multitude of project systems. Most importantly, it provides structure and objectivity to seemingly subjective topics and distills the 'best' decisions for the project. Results of the choosing by advantages process are then incorporated into the project.

We will also provide formal, full scale project estimates at major design milestones. These efforts engage the broader subcontractor market, which enables us to maintain competitive participation, validating prior budget iterations and identifying any assumptions that are out of sync with project goals.

B&A's preconstruction process strives to incorporate value management and constructibility. Each iteration of design will be reviewed proactively. By utilizing pull planning, target value design, 'choosing by advantages' and early subcontractor engagement, our preconstruction experience integrates collaboration into an incremental and iterative process that informs the team on value and quality at each critical step. This translates into smooth and easy decision making that eliminates redesign and delivers value.



B&A has the ability to virtually mockup a space to allow for end-users and stakeholders to experience the space.

Top: A virtual mock up space of the gym at Robert Crown Community Center. **Below:** Robert Crown Community Center's gym under construction.



Procurement

All interested subcontractors will be given the opportunity to pre-qualify using B&A's established format available via the TradeTapp application tool and on our website at www.bulley.com.

Contractor Score, an industry tool for assessing a contractor's financial capacity and subsequent ability to successfully fund work, is also utilized. As a registered user of Contractor Score, B&A has access to information to more fully understand a subcontractor's financial position and ability to perform the scope of work.

The project team will review the bids in all categories and recommend the most qualified candidate(s) for the owner's review and approval. We have a database of over 1,000 pre-qualified subcontractors but welcome qualified local and/or owner/architect recommendations.

B&A is very familiar with the public bidding process and will provide all public notices, scopes, supplemental information and invitations for each bid package. Summaries of all bid openings, along with recommendations, will be provided and reviewed by facility committees and for board review/approval.

B&A will follow public bidding screening regulations. As such, all bidders will be required to::

- Submit Contractor's Score (a third party financial review)
- Submit three references and three past project of similar scope
- Provide current workload and contract values
- Submit their EMR as evidence of their safety record

The entire bidding and subcontractor selection process follows an "open book" approach in which all information is accessible to the owner and architect. Both parties are encouraged to participate in the process. It is absolutely essential that the subcontractors selected are capable of doing the work in terms of their experience, quality, knowledge, financial strength, and ability to provide a known

quantity of qualified manpower in order to meet the project's schedule.

CONSTRUCTION

Document Management & Technology

Through value-based decision making and leveraging technology, such as building information modeling (BIM), our project team is able to harness the talents and insights of all team members and optimize results.

B&A will utilize BIM on your project beginning in preconstruction for constructibility analysis, logistical planning, budgeting and to enable the owner to experience spaces and evaluate decisions prior to construction through the use of virtual mock-ups.

B&A's field team is fully equipped with technology as well. The days of stacks of paper in the trailer are long gone and have been replaced with kiosks and iPad's. The most current documents will be stored via Procore, a cloud-based project management system, and viewed either in the trailer on a large monitor or on site via tablets.

Procore will be the centralized location for all electronic documents, punchlist tracking, RFI tracking, and progress photos.



Project information is also available on a project kiosk which can be located where most convenient for all stakeholders.

COST CONTROL

Measures to ensure accurate cost control include:

- Monthly cost reports – a detailed analysis of costs versus the budget for both labor and materials
- Weekly labor cost reports - reports which outline, by activity, labor costs that week
- Subcontractor award/buyout report – a report that tracks the current status of all subcontracts and the value of each versus the GMP
- Contingency report – a detailed summary of the project contingency including why and where funds are being allocated
- Change order log – a comprehensive list of approved and pending change orders so that at any given time the total potential project cost exposure is known

In keeping with the spirit of our firm’s “open book” policy, all of the above information is provided and regularly updated for owner and architect review.

SCHEDULING

Bulley & Andrews’ project team will review the project drawings and generate a list of activities to create the project schedule. The project team’s knowledge and experience will inform the schedule and identify the critical path. The schedule will be the guide for the entire length of the project.

TRANSITION

With our client’s best interest at heart, B&A begins planning the transition to occupancy at the very *start of construction*.

A move-in plan will be developed early in the construction process and the B&A team will schedule multiple site walk-throughs with the Park District of Oak Park to ensure the transition process is well documented and seamless. Discussions regarding furniture, equipment, delivery schedules, phased areas of occupancy and certificate of occupancy requirements will all occur such that there are no surprises regarding the move-in effort.

Turnover of closeout paperwork begins well in advance of project completion, with a goal on every project that O&M manuals be issued for review at 50% project complete. This allows the facility’s staff tasked with maintenance of the new space, ample time to become familiar with the new systems, prior to training and ask valuable questions. This information, as-built documents and warranty statements are all provided in hard and electronic formats. All training sessions are also video recorded and provided along with the electronic closeout documents.

Timely and thorough project close-out is critical to the successful completion of any building project but B&A’s commitment to quality assurance doesn’t end there. B&A routinely contacts our clients at a 10-month post closeout to touch base and address any issues that may be affected by the warranty period. We feel strongly that reminding clients of the warranty option demonstrates our genuine interest in their satisfaction and ensures their needs are being met.

Section 5: Construction Manager Fee Proposal

Reference
New Non-Fiction

Silent Reading Room
Group Study Rooms



Group Study Rooms
Silent Reading Room
Group Study Rooms

Construction Manager Fee Proposal

Construction Manager Fee Proposal

Task	Sub-task	Cost	Notes
Pre-Construction			
	Design and Constructability Evaluation	\$ 7,560	*see Detail sheet for breakdown
	Cost Estimating	\$ 13,420	*see Detail sheet for breakdown
	Permit Preparation	\$ 1,360	*see Detail sheet for breakdown
	Bid Preparation	\$ 15,120	*see Detail sheet for breakdown
	Other Services	\$ 27,500	*see Detail sheet for breakdown
	Reimbursable Items	\$ 3,000	*see Detail sheet for breakdown
	Preconstruction Fee:	\$ 67,960	
Construction			
	CM Fee	2.50%	
	General Liability Insurance	1.00%	
	Payment & Performance Bond	0.78%	
	Subcontractor Default Insurance	1.25%	

Construction Manager Fee Proposal

Preconstruction Fee Detail

Design and Constructability Evaluation										
Name	Title	Quantity/Unit	Unit Costs			Extended Costs			Totals	
			Labor	Material	Equip	Labor	Material	Equip		
Tim Puntillo	President	16 hrs	150						In OH&P	
Peter Kuhn	Project Executive	40 hrs	125			5000			In OH&P	
TBD	Project Manager	40 hrs	85			3400			3400	
Blake MacGregor	Preconstruction Manager	40 hrs	85			3400			3400	
TBD	Superintendent	8 hrs	95			760			760	
		TOTAL HOURS	144	TOTAL DESIGN AND CONSTRUCTABILITY EVALUATION						\$ 7,560

Cost Estimating										
Name	Title	Quantity/Unit	Unit Costs			Extended Costs			Totals	
			Labor	Material	Equip	Labor	Material	Equip		
Tim Puntillo	President	40 hrs	150						In OH&P	
Peter Kuhn	Project Executive	80 hrs	125			10000			In OH&P	
TBD	Project Manager	120 hrs	85			10200			In OH&P	
Blake MacGregor	Preconstruction Manager	120 hrs	85			10200			10200	
Joel Klahn	Diversity Compliance Officer	20 hrs	85			1700			1700	
TBD	Superintendent	16 hrs	95			1520			1520	
		TOTAL HOURS	396	TOTAL COST ESTIMATING						\$ 13,420

PERMIT PREPARATION										
Name	Title	Quantity/Unit	Unit Costs			Extended Costs			Totals	
			Labor	Material	Equip	Labor	Material	Equip		
Peter Kuhn	Project Executive	8 hrs	125			1000			In OH&P	
Blake MacGregor	Preconstruction Manager	8 hrs	85			680			680	
TBD	Project Manager	8 hrs	85			680			680	
		TOTAL HOURS	24	TOTAL PERMIT PREPARATION						\$ 1,360

BID PREPARATION										
Name	Title	Quantity/Unit	Unit Costs			Extended Costs			Totals	
			Labor	Material	Equip	Labor	Material	Equip		
Peter Kuhn	Project Executive	40 hrs	125						In OH&P	
TBD	Project Manager	80 hrs	85			6800			6800	
Blake MacGregor	Preconstruction Manager	80 hrs	85			6800			6800	
TBD	Superintendent	16 hrs	95			1520			1520	
		TOTAL HOURS	216	TOTAL BID PREPARATION						\$ 15,120

OTHER SERVICES - Logistics Planning, Phasing, Sequencing, Scheduling										
Name	Title	Quantity/Unit	Unit Costs			Extended Costs			Totals	
			Labor	Material	Equip	Labor	Material	Equip		
Peter Kuhn	Project Executive	40 hrs	125						In OH&P	
TBD	Project Manager	80 hrs	85			6800			6800	
Blake MacGregor	Preconstruction Manager	80 hrs	85			6800			6800	
Dana Erdman	Director Innovation and Tech	120 hrs	100			12000			12000	
TBD	Superintendent	20 hrs	95			1900			1900	
		TOTAL HOURS	340	TOTAL OTHER SERVICES						\$ 27,500



Memo

To: Kassie Porreca, Chair, Administration & Finance Committee
Board of Park Commissioners

From: Diane Stanke, Director of Marketing and Customer Service

CC: Jan Arnold, Executive Director

Date: March 11, 2020

Re: Brochure Bid



Statement

Bid specifications for the 2020-2021 Brochure Series were posted on the Park District website on January 31, and emails were sent to three printing companies who had asked to be notified. Three companies submitted sealed bids for brochure printing services which were opened and read aloud on February 17, 2020, at 1:00pm. A summary table of the results is attached.

Discussion

Schumann Press, Inc. from Fall River, WI, submitted the lowest base bid of \$80,487.23 for four issues with a four color cover and body and additional inserts in the spring issue (annual report) and summer issue (concerts, pools and movie schedules and FLW Races promo). The Park District has never worked with Schumann Press. The next lowest bid was from Paulson Press, at \$89,500, who has been printing the Park District brochure since winter 2009. Melissa Martinez and Laura Pulido went on an on-site tour of Schumann Press on Wednesday, February 26, with Account Representative Jim McCormick. All three references were also contacted with favorable comments received.

Included in the bid packet, was a request for an alternate bid for the printing of the 2021-2022 brochure series. Schumann Press was also the low bidder for the alternate bid at \$81,694.54 as compared to the next lowest bid of \$92,000 from Paulson Press. Schumann Press was also the low bidder on an additional alternate bid for the 2022-2023 brochure series with a price bid of \$82,919.86 as compared to a bid of \$94,000 from Paulson Press.

The bid from Schumann Press is below the 2020 budget allocation of \$95,825 for brochure printing.

Conclusion

The Administration and Finance Committee recommends that the Board of Commissioners accept the base bid for printing the 2020-2021 from Schumann Press, Inc. from Fall River, WI, to print the Park District of Oak Park's 2020-2021 Brochure Series in the amount of \$80,487.23. Additionally, give Executive Director Arnold authorization to extend two additional years based on the printed brochures meeting the expectations of the District.

Attachment: Bid Tabulation

